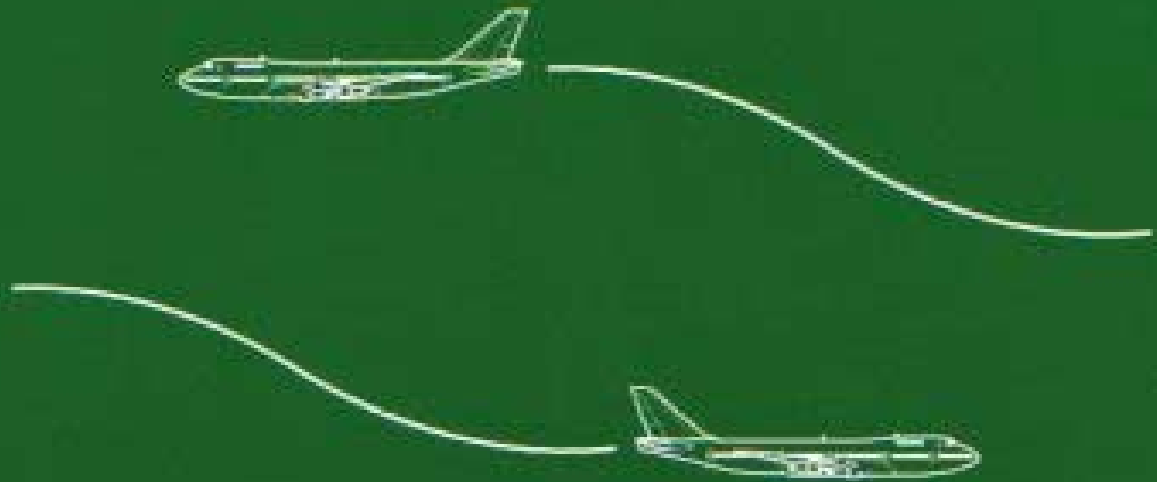

Introduction to **TCAS II** *Version 7*



U.S. Department of Transportation
Federal Aviation Administration

November 2000

Preface

This booklet provides the background for a better understanding of the Traffic Alert and Collision Avoidance System (TCAS II) by personnel involved in the implementation and operation of TCAS II. This booklet is an update of a similar booklet published in 1990 by the Federal Aviation Administration (FAA). This update describes TCAS II Version 7.

Table of Contents

PREFACE	2
THE TCAS SOLUTION	5
BACKGROUND	6
TCAS II DEVELOPMENT.....	7
IN-SERVICE OPERATIONAL EVALUATIONS	8
TOWARD A REQUIREMENT FOR WORLDWIDE CARRIAGE	9
STANDARDS AND GUIDANCE MATERIAL	10
TCAS II TECHNICAL DESCRIPTION	11
SYSTEM COMPONENTS.....	11
<i>Mode S/TCAS Control Panel</i>	11
<i>Antennas</i>	12
<i>Cockpit Presentation</i>	12
Traffic Display	12
Resolution Advisory Display	14
TARGET SURVEILLANCE	17
MODE S SURVEILLANCE.....	17
MODE C SURVEILLANCE	17
INTERFERENCE LIMITING.....	20
ELECTROMAGNETIC COMPATIBILITY	20
COLLISION AVOIDANCE CONCEPTS	21
SENSITIVITY LEVEL.....	21
TAU	22
PROTECTED VOLUME	23
CAS LOGIC FUNCTIONS	26
TRACKING	26
TRAFFIC ADVISORY	27
THREAT DETECTION.....	27
RESOLUTION ADVISORY SELECTION	28
TCAS/TCAS COORDINATION.....	30
ADVISORY ANNUNCIATION	31
AIR/GROUND COMMUNICATIONS	32
TRAFFIC ADVISORY DISPLAY	32
RESOLUTION ADVISORY DISPLAYS	32
AURAL ANNUNCIATIONS	32
PERFORMANCE MONITORING	32
USE OF TCAS	34
REGULATIONS AND OPERATIONAL GUIDANCE	34
<i>Controllers Responsibilities</i>	34
<i>Pilot Responsibilities</i>	35
OPERATIONAL EXPERIENCE.....	37
TRAINING PROGRAMS	38
<i>Pilot Training Programs</i>	39
<i>Controller Training Programs</i>	39
SUMMARY	40

ABBREVIATIONS	41
GLOSSARY	42
BIBLIOGRAPHY	45

The TCAS Solution

After many years of extensive analysis, development, and flight evaluation by the Federal Aviation Administration (FAA), other countries' Civil Aviation Authorities (CAAs), and the aviation industry, a solution has been found to reduce the risk of midair collisions between aircraft. This solution is known as the Traffic Alert and Collision Avoidance System or TCAS. In the international arena, the system is known as the Airborne Collision Avoidance System or ACAS.

TCAS is a family of airborne devices that function independently of the ground-based air traffic control (ATC) system and provide collision avoidance protection for a broad spectrum of aircraft types.

TCAS I provides traffic advisories (TA) and proximity warning of nearby traffic to assist the pilot in the visual acquisition of intruder aircraft. TCAS I is mandated for use in the United States for turbine-powered, passenger-carrying aircraft having more than 10 and less than 31 seats. TCAS I is also used by a number of general aviation fixed and rotary wing aircraft.

TCAS II provides traffic advisories and resolution advisories (RA), i.e., recommended escape maneuvers, in the vertical dimension to either increase or maintain the existing vertical separation between aircraft. Airline aircraft, including regional airline aircraft with more than 30 seats, and general aviation turbine-powered aircraft use TCAS II equipment.

The TCAS concept uses the same radar beacon transponders installed on aircraft to operate with ATC ground-based radars. The level of protection provided by TCAS equipment depends on the type of transponder the target aircraft is carrying. The level of protection is outlined in Table 1. It should be noted that TCAS provides no protection

against aircraft that do not have an operating transponder.

Table 1. TCAS Levels of Protection

		Own Aircraft Equipment	
		TCAS I	TCAS II
Target Aircraft Equipment	Mode A XPDR ONLY	TA	TA
	Mode C or MODE S XPDR	TA	TA and Vertical RA
	TCAS I	TA	TA and Vertical RA
	TCAS II	TA	TA and Coordinated Vertical RA

Based on a Congressional mandate (Public Law 100-223), the FAA has issued a rule that requires all passenger-carrying aircraft with more than 30 seats be equipped with TCAS II.

Since the early 1990s, an operational evaluation, known as the TCAS Transition Program (TTP), has collected and analyzed a significant amount of data related to the performance and use of TCAS II in both the U.S. National Airspace System (NAS) and in other airspace worldwide. As a result of these analyses, changes to TCAS II have been developed, tested, and implemented. The latest changes, collectively known as TCAS II Version 7, were certified in early 2000 and are now being implemented by the industry.

TCAS II Version 7 is the only version of TCAS II that complies with the ICAO Standards and Recommended Practices (SARPs) for ACAS II. As such, Version 7 is currently being mandated for carriage in certain countries or regions, e.g., Europe, Australia, and India, and has been mandated for carriage in 2003 by the International Civil Aviation Organization (ICAO).

Background

The development of an effective airborne collision avoidance system has been a goal of the aviation industry for a number of years. As air traffic has continued to grow over the years, development of and improvements to ATC systems and procedures have made it possible for controllers and pilots to cope with this increase in operations, while maintaining the necessary levels of flight safety. However, the risk of airborne collision remains. That is why, as early as the 1950s, the concept and initial development of an airborne collision avoidance system, acting as a last resort, was being considered.

A series of midair collisions that occurred in the United States, has been the impetus for the development and refinement of an airborne collision avoidance system. These tragic milestones included the following collisions:

- In 1956, the collision between two airliners over the Grand Canyon spurred both the airlines and the aviation authorities to initiate system development studies for an effective system.
- In 1978, the collision between a light aircraft and an airliner over San Diego led the FAA to initiate the development of **TCAS**.
- Finally, in 1986, the collision between a DC-9 and a private aircraft over Cerritos, California, resulted in a Congressional mandate that required some categories of American and foreign aircraft to be equipped with TCAS for flight operations in U.S. airspace.

In parallel to the development of TCAS equipment in the United States, ICAO has been working since the early 1980s to develop standards for **ACAS**. **ICAO officially recognized ACAS on 11 November 1993**. Its descriptive definition appears in Annex 2 of the Convention on

International Civil Aviation and its use is regulated in Procedures for Air Navigation Services — Aircraft Operations (PANS-OPS) and Procedures for Air Navigation Services — Rules of the Air and Air Traffic Services (PANS-RAC). In November 1995, the SARPs and Guidance Material for ACAS II were approved, and they appear in Annex 10 of the Convention on International Civil Aviation.

During the late 1950s and early 1960s, collision avoidance development efforts included an emphasis on passive and noncooperating systems. These concepts proved to be impractical. One major operational problem that could not be overcome with these designs was the need for nonconflicting, complementary avoidance maneuvers that require a high-integrity communications link between aircraft involved in the conflict.

One of the most important developments in the collision avoidance concept was the derivation of the range/range rate, or tau, concept by Dr. John S. Morrell of Bendix. This concept is based on time, rather than distance, to the closest point of approach in an encounter.

During the late 1960s and early 1970s, several manufacturers developed aircraft collision avoidance systems based on interrogator/transponder and time/frequency techniques. Although these systems functioned properly during staged aircraft encounter testing, the FAA and the airlines jointly concluded that in normal airline operations, they would generate a high rate of unnecessary alarms in dense terminal areas. This problem would have undermined the credibility of the system with the flight crews. In addition, each target aircraft would have to be equipped with the same equipment to provide protection to an equipped aircraft.

In the mid 1970s, the Beacon Collision Avoidance System (BCAS) was developed. BCAS used reply data from the Air Traffic

Control Radar Beacon System (ATCRBS) transponders to determine an intruder's range and altitude. At that time, ATCRBS transponders were installed in all airline and military aircraft and a large number of general aviation aircraft. Thus, any BCAS-equipped aircraft would be able to detect and be protected against the majority of other aircraft in the air without imposing additional equipment requirements on those other aircraft. In addition, the discrete address communications techniques used in the Mode S transponders then under development permitted two conflicting BCAS aircraft to perform coordinated escape maneuvers with a high degree of reliability.

TCAS II development

In 1981, the FAA made a decision to develop and implement TCAS utilizing the basic BCAS design for interrogation and tracking, but providing additional capabilities.

TCAS is designed to work autonomously of the aircraft navigation equipment and independently of the ground systems used to provide ATC services. TCAS interrogates ICAO-compliant transponders of all aircraft in the vicinity and based on the replies received, tracks the slant range, altitude (when it is included in the reply message), and bearing of surrounding traffic. From several successive replies, TCAS calculates a time to reach the CPA (Closest Point of Approach) with the intruder, by dividing the range by the closure rate. This time value is the main parameter for issuing alerts. If the transponder replies from nearby aircraft includes their altitude, TCAS also computes the time to reach co-altitude. TCAS can issue two types of alerts:

- TAs to assist the pilot in the visual search for the intruder aircraft and to prepare the pilot for a potential RA; and
- RAs to recommend maneuvers that will either increase or maintain the existing vertical separation from an intruder

aircraft. When the intruder aircraft is also fitted with TCAS II, both TCAS' coordinate their RAs through the Mode S data link to ensure that complementary resolution senses are selected.

TCAS II is designed to operate in traffic densities of up to 0.3 aircraft per square nautical mile (nmi), i.e., 24 aircraft within a 5 nmi radius, which is the highest traffic density envisioned over the next 20 years.

Development of the TCAS II collision avoidance algorithms included the completion of millions of computer simulations to optimize the protection provided by the system, while minimizing the frequency of unacceptable or nuisance advisories. In addition to these computer simulations, early versions of the collision avoidance algorithms were evaluated via pilot in the loop simulations and during the operation of prototype equipment in FAA aircraft throughout the NAS.

Extensive safety studies were also performed to estimate the safety improvements that could be expected with the introduction of TCAS into service. These safety studies have been continuously updated throughout the refinement of the collision avoidance algorithms. The safety studies have shown that TCAS II will resolve nearly all of the critical near midair collisions involving airline aircraft. However, TCAS cannot handle all situations. In particular, it is dependent on the accuracy of the threat aircraft's reported altitude and on the expectation that the threat aircraft will not make an abrupt maneuver that defeats the TCAS RA. The safety study also shows that TCAS II will induce some critical near midair collisions, but overall, the number of near midair collisions with TCAS is less than 10% of the number that would have occurred without the presence of TCAS.

Extensive studies were also carried out to evaluate the interaction between TCAS and

ATC. The analysis of ATC radar data showed that in 90% of the cases, the vertical displacement required to resolve an RA was less than 300 feet. Based on these studies, it was concluded that the possibility of the response to a TCAS RA causing an aircraft to infringe on the protected airspace for another aircraft was remote. However, operational experience has shown that the actual displacement resulting from an RA response is often much greater than 300 feet, and TCAS has had an adverse affect on the controllers and the ATC system. Because of this operational experience, Version 7 contains numerous changes and enhancements to the collision avoidance algorithms, the aural annunciations, the RA displays, and pilot training programs to minimize the displacement while responding to an RA.

In-Service Operational Evaluations

To ensure that TCAS performed as expected in its intended operational environment, several operational evaluations of the system have been conducted. These evaluations provided a means for the pilots using TCAS and the controllers responsible for providing separation services to TCAS-equipped aircraft to have a direct influence on the final system design and performance requirements.

The initial operational evaluation of TCAS was conducted by Piedmont Airlines in 1982. Using a TCAS II prototype unit manufactured by Dalmo Victor, Piedmont flew approximately 900 hours in scheduled, revenue service while recording data on the performance of TCAS. These recorded data were analyzed to assess the frequency and suitability of the TAs and RAs. During this evaluation, the TCAS displays were not visible to the pilots, and observers from the aviation industry flew with the aircraft to monitor the system performance and to provide technical and operational comments on its design.

In 1987, Piedmont flew an upgraded version of the Dalmo Victor equipment for approximately 1200 hours. During this evaluation, the TCAS displays were visible to the pilots and the pilots were permitted to use the information provided to maneuver the aircraft in response to RAs. This installation included a dedicated TCAS data recorder so that quantitative data could be obtained on the performance of TCAS. In addition, pilot and observers completed questionnaires following each TA and RA so that assessments could be made regarding the value of the system to the flight crews.

This evaluation also provided the basis for the development of avionics certification criteria for production equipment, validated pilot training guidelines, provided the justification for improvements to the TCAS algorithms and displays, and validated the pilot procedures for using the equipment.

Following the successful completion of the second Piedmont evaluation, the FAA initiated the Limited Installation Program (LIP). Under the LIP, Bendix-King and Honeywell built and tested commercial quality, pre-production TCAS II equipment that was in compliance with the TCAS II Minimum Operational Performance Standards (MOPS). Engineering flight tests of this equipment were conducted on the manufacturers' aircraft, as well as FAA aircraft. Using data collected during these flight tests, together with data collected during factory and ground testing, both manufacturers' equipment was certified via a Supplemental Type Certificate (STC) for use in commercial, revenue service.

The Bendix-King units were operated by United Airlines on a B737-200 and a DC8-73 aircraft. Northwest Airlines operated the Honeywell equipment on two MD-80 aircraft. Over 2000 hours of operating experience were obtained with the United aircraft and approximately 2500 hours of operating experience were obtained with the Northwest installations.

The experience provided by these operational evaluations resulted in further enhancements to the TCAS II logic, improved test procedures, and finalized the procedures for certification of production equipment. The most important information obtained from the operational evaluations was the nearly unanimous conclusion that TCAS II was safe, operationally effective, and ready for more widespread implementation.

With the successful completion of these early operational evaluations, there was a high degree of confidence that a system with sufficient maturity was available to meet the Congressionally mandated implementation of TCAS II in U.S. airspace.

As part of this mandated implementation, the largest operational evaluation of TCAS, known as the TTP, was initiated. The TTP began in late 1991 and has continued through the initial implementation, the mandated upgrade to Version 6.04A Enhanced, and is still active as Version 7 enters operation. In conjunction with the TTP in the U.S., EUROCONTROL has conducted extensive evaluations of TCAS operations in Europe, and the Japan Civil Aviation Bureau (JCAB) has conducted similar assessments of TCAS II performance in Japanese and surrounding airspace. Other countries also conducted operational evaluations as the use of TCAS increased during the past 10 years.

The system improvements suggested as a result of these TCAS II evaluations led to the development and release of Version 6.04A Enhanced in 1993. The principal aim of this modification was the reduction of nuisance alerts, which were occurring at low altitudes and during level-off encounters, and the correction of a problem in the altitude crossing logic.

After the implementation of Version 6.04A Enhanced, operational evaluations continued with the same objective, and proposed performance improvements led to the

development of Version 7. The MOPS for Version 7 was approved in December 1997 and Version 7 units became available for installation in late 1999. Version 7 is expected to further improve TCAS compatibility with the air traffic control system throughout the world.

Toward a Requirement for Worldwide Carriage

The United States was the first member of ICAO to mandate carriage of an airborne collision avoidance system for passenger carrying aircraft operating in its airspace.

Because of this mandate, the number of long-range aircraft fitted with TCAS II and operating in European and Asian airspace continued to increase, although the system carriage and operation were not mandatory in this airspace. As studies, operational experience, and evaluations continued to demonstrate the safety benefits of TCAS II, some non-U.S. airlines also equipped their short-haul fleets with TCAS.

In 1995, the EUROCONTROL Committee of Management approved an implementation policy and schedule for the mandatory carriage of TCAS II in Europe. The European Air Traffic Control Harmonization and Integration Program (EATCHIP) Project Board then ratified this policy. The approved policy requires the following:

- From 1 January 2000, all civil fixed-wing, turbine-powered aircraft having a maximum take-off mass exceeding 15,000 kg, or a maximum approved passenger seating configuration of more than 30, will be required to be equipped with TCAS II, Version 7; and
- From 1 January 2005, all civil fixed-wing, turbine-powered aircraft having a maximum take-off mass exceeding 5,700 kg, or a maximum approved passenger seating configuration of more than 19, will be required to be equipped with TCAS II, Version 7.

Because of delays in obtaining Version 7 equipment, a number of exemptions to the 1 January 2000 date were granted by EUROCONTROL. Each of the exemptions granted have a unique end date for the exemption, but all exemptions will expire on 31 March 2001.

Other countries, including Argentina, Australia, Chile, Egypt, India, and Japan, have also mandated carriage of TCAS II avionics on aircraft operating in their respective airspace.

The demonstrated safety benefits of the equipment, and the 1996 midair collision between a Saudia Boeing 747 and a Kazakhstan Ilyushin 76, resulted in an ICAO proposal for worldwide mandatory carriage of ACAS II on all aircraft, including cargo aircraft, beginning in 2003. To guarantee the effectiveness of this mandate, ICAO has also mandated the carriage and use of pressure altitude reporting transponders, which are a prerequisite for generating RAs.

After the mid-air collision between a German Air Force Tupolev 154 and a U.S. Air Force C-141 transport aircraft, off Namibia in September 1997, urgent consideration was given to the need to equip military transport aircraft with TCAS. Although only a limited number of countries have included military and other government-owned aircraft in their mandates for TCAS carriage, several countries, including the United States, have initiated programs to equip tanker, transport, and cargo aircraft within their military fleets with TCAS II Version 7.

Standards and Guidance Material

The data obtained from the FAA and industry sponsored studies, simulations, flight tests, and operational evaluations have enabled RTCA to publish the MOPS for TCAS II. The current version of the MOPS, DO-185A,

describes the standards, requirements, and test procedures for TCAS Version 7.

RTCA has also published MOPS for TCAS I, DO-197A, which defines the requirements and test procedures for TCAS I equipment intended for use on airline aircraft operated in revenue service.

The FAA has issued Technical Standard Order (TSO) C118a that defines the requirements for the approval of TCAS I equipment. A draft Advisory Circular outlining the certification requirements and the requirements for obtaining operational approval of the system has been prepared and is being used by the FAA's Aircraft Certification Offices (ACO) as the basis for approving TCAS I installations and operation.

For TCAS II, TSO C119b and Advisory Circular 20-131a have been published for use by FAA airworthiness authorities in certifying the installation of TCAS II on various classes of aircraft. Advisory Circular 120-55a defines the procedures for obtaining operational approval for the use of TCAS II. While the FAA developed these documents, they have been used throughout the world by civil aviation authorities to approve the installation and use of TCAS.

ICAO SARPs and Guidance Material for ACAS I and ACAS II have been published in Annex 10. The procedures for use of ACAS have been published in PANS-RAC and PANS-OPS. These documents provide international standardization for collision avoidance systems.

For the avionics, the Airlines Electronic Engineering Committee (AEEC) has completed work on ARINC Characteristic 735 to define the form, fit, and function of TCAS II units. Similar work on the Mode S transponder has been completed, and the results of that work are contained in ARINC Characteristic 718.

TCAS II Technical Description

System components

Figure 1 is a block diagram of TCAS II. A TCAS II installation consists of the following major components.

TCAS Computer Unit

The TCAS Computer Unit, or TCAS Processor, performs airspace surveillance, intruder tracking, its own aircraft altitude tracking, threat detection, RA maneuver determination and selection, and generation of advisories. The TCAS Processor uses pressure altitude, radar altitude, and discrete aircraft status inputs from its own aircraft to control the collision avoidance logic parameters that determine the protection volume around the TCAS aircraft. If a tracked aircraft is a collision threat, the processor selects an avoidance maneuver that will provide adequate vertical miss distance from the intruder while minimizing the perturbations to the existing flight path. If the threat aircraft is also equipped with TCAS II, the avoidance maneuver will be coordinated with the threat aircraft.

Figure 1. TCAS II Block Diagram

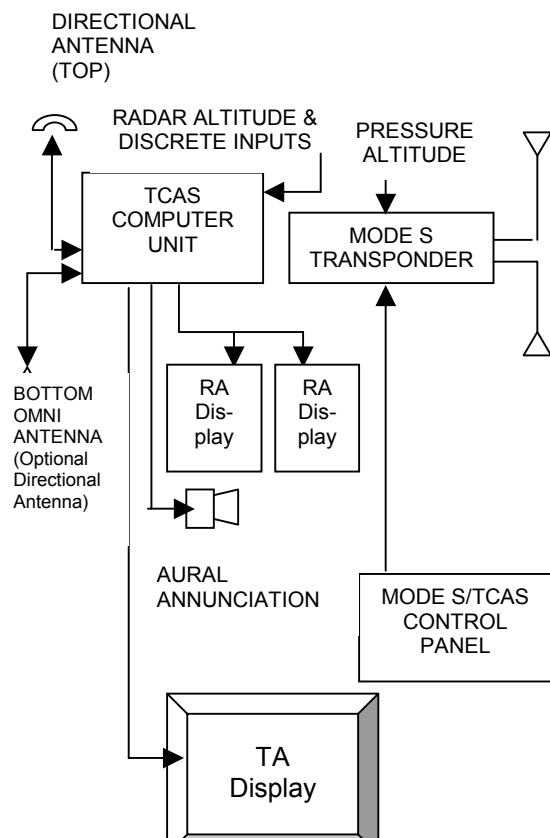
Mode S Transponder

A Mode S transponder is required to be installed and operational for TCAS II to be operational. If the Mode S transponder fails, the TCAS Performance Monitor will detect this failure and automatically place TCAS into Standby. The Mode S transponder performs the normal functions to support the ground-based ATC system and can work with either an ATCRBS or a Mode S ground sensor. The Mode S transponder is also used to provide air-to-air data exchange between TCAS-equipped aircraft so that coordinated, complementary RAs can be issued when required.

Mode S/TCAS Control Panel

A single control panel is provided to allow the flight crew to select and control all TCAS equipment, including the TCAS Processor, the Mode S transponder, and in some cases, the TCAS displays. A typical control panel provides four basic control positions:

- **Stand-by:** Power is applied to the TCAS Processor and the Mode S transponder, but TCAS does not issue any interrogations and the transponder will reply to only discrete interrogations.
- **Transponder:** The Mode S transponder is fully operational and will reply to all appropriate ground and TCAS interrogations. TCAS remains in Standby.
- **TA Only:** The Mode S transponder is fully operational. TCAS will operate normally and issue the appropriate



interrogations and perform all tracking functions. However, TCAS will only issue TAs, and the RAs will be inhibited.

- **Automatic or TA/RA:** The Mode S transponder is fully operational. TCAS will operate normally and issue the appropriate interrogations and perform all tracking functions. TCAS will issue TAs and RAs, when appropriate.

As indicated in Figure 1, all TCAS control signals are routed through the Mode S transponder.

Antennas

The antennas used by TCAS II include a directional antenna that is mounted on the top of the aircraft and either an omnidirectional or a directional antenna mounted on the bottom of the aircraft. Most installations use the optional directional antenna on the bottom of the aircraft.

These antennas transmit interrogations on 1030 MHz at varying power levels in each of four 90° azimuth segments. The bottom-mounted antenna transmits fewer interrogations and at a lower power than the top-mounted antenna. These antennas also receive transponder replies, at 1090 MHz, and send these replies to the TCAS Processor. The directional antennas permit the partitioning of replies to reduce synchronous garbling.

In addition to the two TCAS antennas, two antennas are also required for the Mode S transponder. One antenna is mounted on the top of the aircraft while the other is mounted on the bottom. These antennas enable the Mode S transponder to receive interrogations at 1030 MHz and reply to the received interrogations at 1090 MHz. The use of the top- or bottom-mounted antenna is automatically selected to optimize signal strength and reduce multipath interference.

TCAS operation is automatically suppressed whenever the Mode S transponder is transmitting to ensure that TCAS does not track its own aircraft.

Cockpit Presentation

The TCAS interface with the pilots is provided by two displays — the traffic display and the RA display. These two displays can be implemented in a number of ways, including displays that incorporate both displays into a single, physical unit. Regardless of the implementation, the information displayed is identical. The standards for both the traffic display and the RA display are defined in DO-185A.

Traffic Display

The traffic display, which can be implemented on either a part-time or full-time basis, depicts the position of nearby traffic,

relative to its own aircraft. It is designed to provide information that will assist the pilot in visual acquisition of other aircraft. If implemented on a part-time basis, the display will automatically activate whenever a TA or an RA is issued. Current implementations include dedicated traffic displays; display of the traffic information on shared weather radar displays, MAP displays, Engine Indication and Crew Alerting System (EICAS) displays; and other multifunction displays.

A majority of the traffic displays also provide the pilot with the capability to select multiple ranges and to select the altitude band for the traffic to be displayed. These capabilities allow the pilot to display traffic at longer ranges and with greater altitude separation while in cruise flight, while retaining the capability to select lower display ranges in terminal areas to reduce the amount of display clutter.

Traffic Display Symbolology

Both color and shape are used to assist the pilot in interpreting the displayed information.

The own aircraft is depicted as either a white or cyan arrowhead or airplane-like symbol. The location of the own aircraft symbol on the display is dependent on the display implementation. Other aircraft are depicted using geometric symbols, depending on their threat status, as follows:

- An unfilled diamond (◊), shown in either cyan or white, but not the same color as the own aircraft symbol, is used to depict non-threat traffic.
- A filled diamond (◆), shown in either cyan or white, but not the same color as the own aircraft symbol, is used to depict Proximate Traffic. Proximate Traffic is non-threat traffic that is within 6 nmi and ± 1200 ft from own aircraft.

- A filled amber or yellow circle (●) is used to display intruders that have caused a TA to be issued.
- A filled red square (■) is used to display intruders that have caused an RA to be issued.

Each symbol is displayed on the screen according to its relative position to own aircraft. To aid the pilot in determining the range to a displayed aircraft, the traffic display provides range markings at one-half the selected scale and at the full scale. Additional range markings may be provided at closer ranges, e.g., 2 nmi, on some display implementations. The selected display range is also shown on the display. The range markings and range annunciation are displayed in the same color as the own aircraft symbol unless the traffic display is integrated with an existing display that already provides range markings, e.g., a MAP display.

Vertical speed information and altitude information are also provided for all displayed traffic that are reporting altitude. Relative altitude is displayed in hundreds of feet above the symbol if the intruder is above own aircraft and below the symbol if the intruder is below own aircraft. When the intruder is above the own aircraft, the relative altitude information is preceded by a + sign. When the intruder is below the own aircraft, a – sign precedes the relative altitude information. In some aircraft, the flight level of the intruder can be displayed instead of its relative altitude. The flight level is shown above the traffic symbol if the intruder is above the own aircraft and below the traffic symbol if the intruder is below the own aircraft. If the intruder is not reporting its altitude, no altitude information is shown for the traffic symbol. The altitude information is displayed in the same color as the aircraft symbol.

An arrow is displayed immediately to the right of a traffic symbol when the target

aircraft is reporting its altitude and is climbing or descending at more than 600 fpm. An up arrow is used for a climbing aircraft; a down arrow is used for a descending aircraft. The arrow is displayed in the same color as the aircraft symbol.

When an aircraft causing a TA or RA is beyond the currently selected range of the traffic display, half TA or RA symbols will be displayed at the edge of the display at the proper relative bearing. In some implementations, a written message such as TRAFFIC, TFC, or TCAS is displayed on the traffic display if the intruder is beyond the selected display range. The half symbol or the written message will remain displayed until the traffic moves within the selected display range; the pilot increases the range on a variable range display to allow the intruder to be displayed; or the pilot selects a display mode that allows traffic to be displayed.

In some instances, TCAS may not have a reliable bearing for an intruder causing a TA or RA. Because bearing information is used for display purposes only, the lack of bearing information does not affect the ability of TCAS to issue TAs and RAs. When a “No-Bearing” TA or RA is issued, the threat level, as well as the range, relative altitude, and vertical rate of the intruder, are written on the traffic display. This text is shown in red for an RA and in amber or yellow for a TA. For example, if an RA was issued against an intruder at a range of 4.5 nmi and with a relative altitude of +1200 feet and descending, the “No Bearing” indication on the traffic display would be:

RA 4.5 +12↓

Figure 2 shows the use of the various traffic symbology used on the traffic display.

Resolution Advisory Display

The RA display provides the pilot with information on the vertical speed or pitch angle to fly or avoid to resolve an encounter. The RA display is typically implemented on an instantaneous vertical speed indicator (IVSI); a vertical speed tape that is part of a Primary Flight Display (PFD); or using pitch cues displayed on the PFD. RA guidance has also been implemented on a Heads-Up Display (HUD). The implementations using the IVSI or a vertical speed tape use red and green lights or markings to indicate the vertical speeds to be avoided (red) and the desired vertical speed to be flown (green). An implementation using pitch cues uses a unique shape on the PFD to show the pitch angle to be flown or avoided to resolve an encounter. HUD implementations also use a unique shape to indicate the flight path to be flown or avoided to resolve an encounter.

In general, the round-dial IVSI implementation is used on the older nonglass aircraft. However, some operators have implemented this display in their glass aircraft to provide a common display across their fleet types. Some IVSI implementations use mechanical instruments with a series of red and green LEDs around the perimeter of the display, while other implementations use an LCD display that draws the red and green arcs at the appropriate locations. The LCD display implementations also have the capability to provide both the traffic and RA display on a single instrument.

On glass aircraft equipped with a PFD, some airframe manufacturers have implemented the RA display on the vertical speed tape; some have elected to provide pitch cues; and other implementations provide both pitch cues and a vertical speed tape.

The standards for the implementation of RA displays are provided in DO-185A. In addition to the implementations outlined above, DO-185A defines requirements for

implementation of the RA display via the flight director and a HUD.

Two RA displays are required — one in the primary field of view of each pilot.

Figure 3 shows an RA display implemented on an LCD display that also provides traffic information. Figure 4 shows the two possible implementations on the PFD.


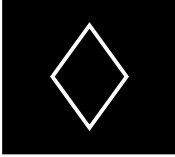

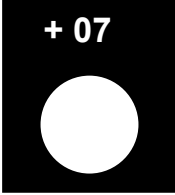
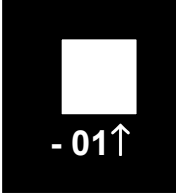
	Own Aircraft. Airplane Symbol in White or Cyan
	Non Intruding Traffic Altitude Unknown Open Diamond in White or Cyan
	Proximity Traffic, 200 Feet Below and Descending. Solid Diamond in White or Cyan.
	Traffic Advisory (Intruder). 700 Feet above and level. Solid Amber Circle.
	Resolution Advisory (Threat). 100 Feet Below and Climbing. Solid Red Square

Figure 2. Standardized Symbology for Use on the Traffic Display

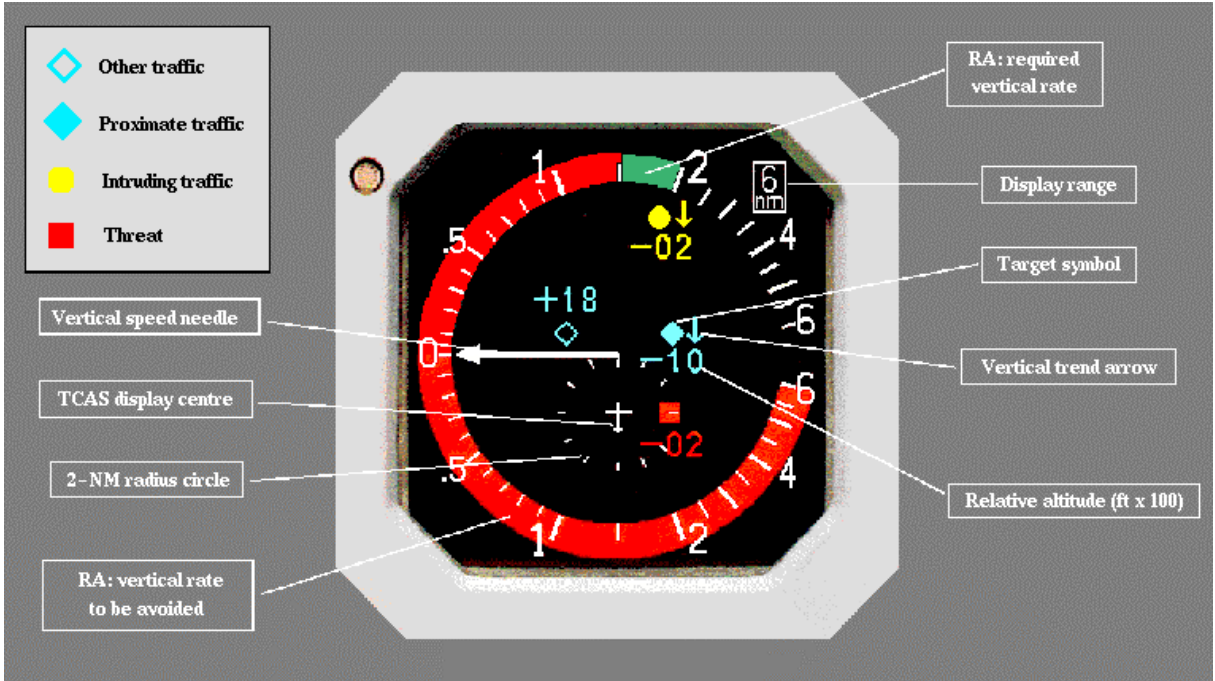
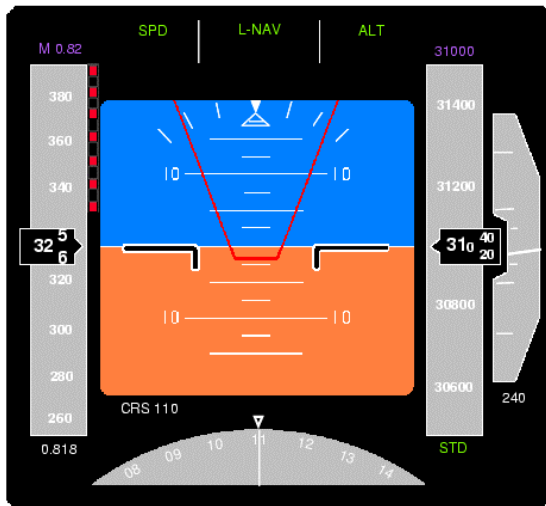
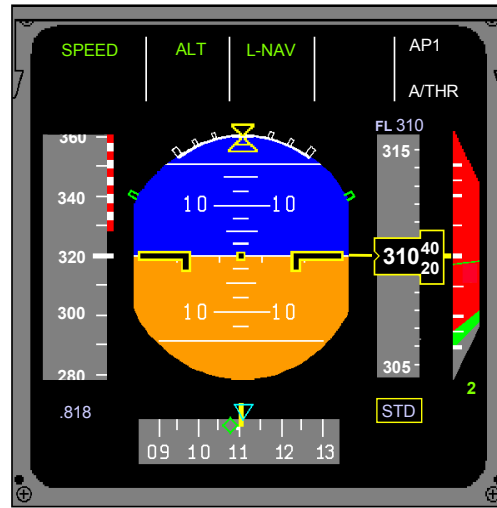


Figure 3. TCAS RA Display Implemented on an IVSI



Pitch Cue Implementation



Vertical Speed Tape Implementation

Figure 4. TCAS RA Displays Implemented on a PFD

Target Surveillance

TCAS, independent of any ground inputs, performs surveillance of nearby aircraft to provide information on the position and altitude of these aircraft so the collision avoidance algorithms can perform their function. The TCAS surveillance function operates by issuing interrogations at 1030 MHz that transponders on nearby aircraft respond to at 1090 MHz. These replies are received and decoded by the surveillance portion of the TCAS software and the information is then provided to the collision avoidance algorithms.

TCAS has a requirement to provide reliable surveillance out to a range of 14 nmi and in traffic densities of up to 0.3 aircraft per square nautical mile. The surveillance function provides the range, altitude, and bearing of nearby aircraft to the collision avoidance function so threat determinations can be made and so the information displayed on the traffic display is accurate. The TCAS surveillance is compatible with both the ATCRBS and Mode S transponders.

TCAS can simultaneously track at least 30 transponder-equipped aircraft within its surveillance range.

Because TCAS surveillance operates on the same frequencies as that used by the ground-based ATC radars, there is a requirement imposed on TCAS that it not interfere with the functions of the ATC radars. Several design features have been developed and implemented to allow TCAS to provide reliable surveillance without degrading the performance of the ATC radars.

Mode S Surveillance

Because of the selective address feature of the Mode S system, TCAS surveillance of Mode S equipped aircraft is relatively straightforward. TCAS listens for the spontaneous

transmissions, or squitters, that are generated once per second by the Mode S transponder. Among other information, the squitter contains the unique Mode S address of the sending aircraft.

Following the receipt and decoding of a squitter message, TCAS sends a Mode S interrogation to the Mode S address contained in the squitter. The Mode S transponder replies to this interrogation and the reply information is used by TCAS to determine the range, bearing, and altitude of the Mode S aircraft.

To minimize interference with other aircraft and ATC on the 1030/1090 MHz channels, the rate at which a Mode S aircraft is interrogated by TCAS is dependent on the range and closure rate between the two aircraft. As the target aircraft approaches the area where a TA may be required, the interrogation rate increases to once per second. At extended ranges, a target is interrogated at least once every five seconds.

TCAS tracks the range and altitude of each Mode S target. These target reports are provided to the collision avoidance logic for use in the detection and advisory logic and for presentation to the pilot on the traffic display. The relative bearing of the target is also provided to the collision avoidance logic so that the target's position can be properly shown on the traffic display. The bearing information is not used by the collision avoidance logic for threat detection and advisory selection.

Mode C Surveillance

TCAS uses a modified Mode C interrogation known as the Mode C Only All Call to interrogate nearby Mode A/C transponders. The nominal interrogation rate for these transponders is once per second. Because TCAS does not use Mode A interrogations, the Mode A transponder codes of nearby aircraft are not known to TCAS.

Aircraft that are not equipped with an operating altitude encoder reply to these interrogations with no data contained in the altitude field of the reply. TCAS uses the framing pulses of the reply to initiate and maintain a range and bearing track on these targets. As with the Mode S tracks, these replies are passed to the collision avoidance logic for traffic advisory detection and for presentation on the traffic display.

The replies from aircraft that are capable of providing their Mode C altitude are tracked in range, altitude, and bearing. These target reports are passed to the collision avoidance logic for TA and RA detection and for presentation on the traffic display.

TCAS surveillance of Mode C targets is complicated by problems of synchronous and nonsynchronous garbling, as well as reflections of signals from the ground (multipath). When a Mode C Only All Call interrogation is issued by TCAS, all Mode C transponders that detect the interrogation will reply. Because of the length of the reply message (21 microseconds), all Mode C equipped aircraft within a range difference of 1.7 nmi from the TCAS aircraft will generate replies that garble, or overlap each other, when received by TCAS. This is shown in Figure 5 and is called synchronous garble. Various techniques have been incorporated into TCAS to cope with this condition.

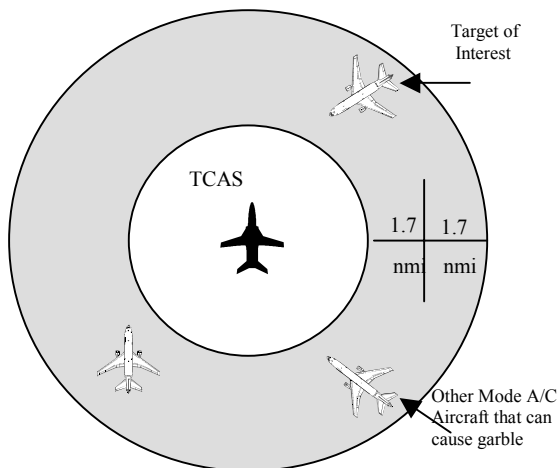


Figure 5. Synchronous Garble Area

Hardware degarblers can reliably decode up to three overlapping replies, and the combined use of variable interrogation power levels and suppression pulses reduces the number of transponders that reply to a single interrogation. This technique, known as whisper-shout (WS) takes advantage of differences between the receiver sensitivity of transponders and the transponder antenna gains of target aircraft.

A low power level is used for the first interrogation step in a WS sequence. During the next WS step, a suppression pulse is first transmitted at a slightly lower level than the first interrogation. The suppression pulse is followed two microseconds later by an interrogation at a slightly higher power level. This action suppresses most of the transponders that had replied to the previous interrogation, but elicits replies from an additional group of transponder that did not reply to the previous interrogation. As shown in Figure 6, the WS procedure is followed progressively in 24 steps, to separate the Mode C replies into several groups, and thus reduces the possibility of garbling. The WS sequence is transmitted once during each surveillance update period, which is nominally one second.

Another technique used to reduce synchronous garble is the use directional transmissions to further reduce the number of potential overlapping replies. This technique is shown in Figure 7. Slightly overlapping coverage must be provided in all directions to ensure 360 degree coverage. Synchronous garble is also reduced by the use of the Mode C Only All Call interrogation. This interrogation inhibits Mode S transponders from replying to a Mode C interrogation.

Nonsynchronous garble is caused by the receipt of undesired transponder replies that were generated in response to interrogations from ground sensors or other TCAS interrogations. These so-called *fruit* replies are transitory so they are typically identified and

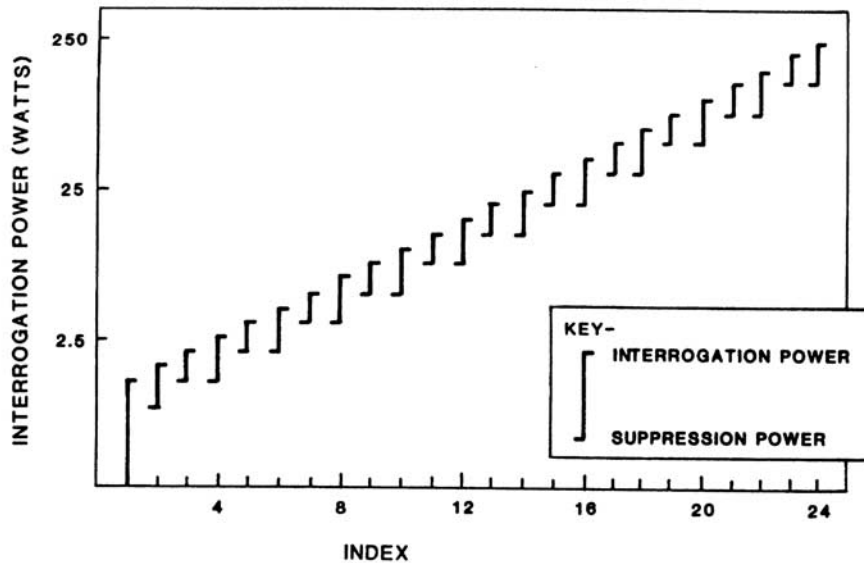


Figure 6. Whisper-Shout Interrogation Sequence

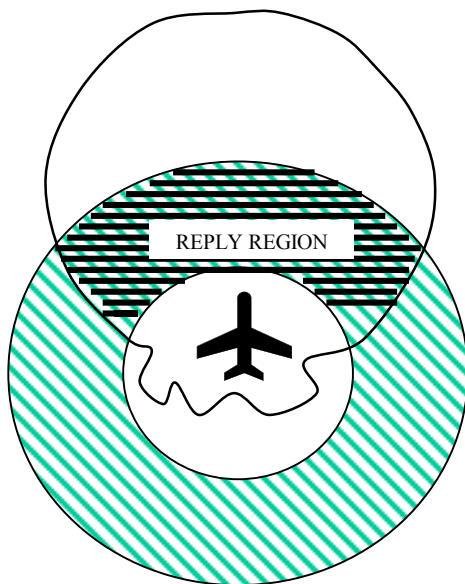


Figure 7. Directional Transmission

discarded by correlation algorithms in the surveillance logic. Operational experience

with TCAS has shown that the probability of initiating and maintaining a track based on fruit replies is extremely remote.

Avoiding the initiation of surveillance tracks based on multipath replies is another important consideration in the design of the TCAS surveillance. Multipath results in the detection of more than one reply to the same interrogation, generally of lower power, from the same aircraft. It is caused by a reflected interrogation and usually occurs over flat terrain. To control multipath, the direct-path power level is used to raise the minimum triggering level (MTL) of the TCAS receiver enough to discriminate against the delayed and lower power reflections. This technique, referred to as Dynamic MTL (DMTL), is shown in Figure 8. As shown in Figure 8, the four-pulse direct reply is above the DMTL level, while the delayed, lower-power multipath reply is below the DMTL threshold, and is thus rejected by TCAS.

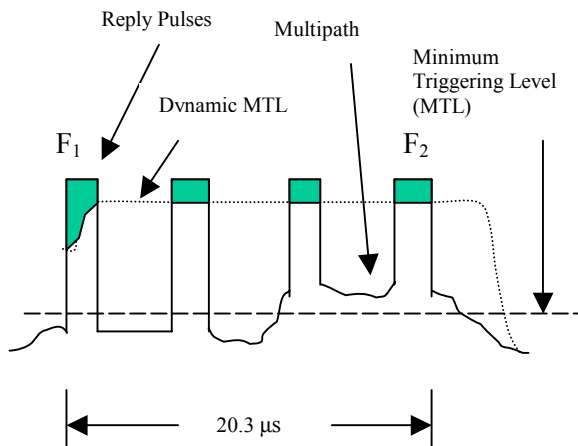


Figure 8. Dynamic Thresholding of ATCRBS Replies

Interference Limiting

Interference limiting is a necessary part of the surveillance function. To ensure that no transponder is suppressed by TCAS activity for more than 2% of the time, and that TCAS does not create an unacceptably high fruit rate for the ground-based ATC radars, multiple TCAS units within detection range of one another, i.e., approximately 30 nmi, are designed to limit their own transmissions under certain conditions. As the number of such TCAS units within this region increases, the interrogation rate and power allocation for each of them must decrease to prevent undesired interference with the ATC radars.

To achieve this, every TCAS unit counts the number of other TCAS units within detection range. This is done by periodically transmitting TCAS broadcast messages that include the Mode S address of the transmitting aircraft every eight seconds. Mode S transponders are designed to accept the broadcast messages without replying. These messages are monitored by the TCAS interference limiting algorithms to develop an estimate of the number of TCAS units within detection range. The number of total TCAS units is used by each TCAS to limit the interrogation rate and power as required.

While interference limiting has been an integral part of TCAS since its inception, initial operational experience with TCAS indicated that refinements were necessary in the surveillance design to meet the above-stated requirements. In Version 7, the interference limiting algorithms have been modified to address problems seen during operation. These modifications account for different distributions in TCAS aircraft in the terminal area because of the increased traffic density near airports.

The modifications also inhibit the interference algorithms at altitudes above Flight Level (FL) 180 and provide longer surveillance ranges in high-density traffic environments. A key feature of the modifications is the guarantee that reliable surveillance will always be available out to a range of six nautical miles. In high density traffic areas at altitudes below FL180, the interrogation rate will be reduced from one per second to once every five seconds for non-threat aircraft that are at least three nautical miles away and are at more than 60 seconds from closest point of approach (CPA).

Electromagnetic Compatibility

TCAS incorporates a number of design features to ensure that TCAS does not interfere with other radio services that operate in the 1030/1090 MHz frequency band. The design of the Mode S waveforms used by TCAS provide compatibility with the Mode A and Mode C interrogations of the ground-based secondary surveillance radar system and the frequency spectrum of Mode S transmissions is controlled to protect adjacent distance measuring equipment (DME) channels.

The interference limiting features of TCAS also help to ensure electromagnetic compatibility with the ATC radar system. An extensive series of analyses, equipment test, and computer simulations have shown that the surveillance design contained in the Version 7

software have demonstrated that operationally significant interference will not occur between TCAS, secondary surveillance radar, and DME systems.

Collision Avoidance Concepts

Airborne collision avoidance is a complex problem. It has taken many years to develop an operationally acceptable solution and the refinement of the system continues to maximize the compatibility between TCAS, ATC systems throughout the world, and existing cockpit procedures. The heart of collision avoidance is the collision avoidance system logic or the CAS logic. To explain the operation of the CAS logic, the basic CAS concepts of sensitivity level, tau, and protected volume need to be understood.

Sensitivity Level

Effective CAS logic operation requires a trade-off between necessary protection and unnecessary advisories. This trade-off is accomplished by controlling the sensitivity level (SL), which controls the time or tau thresholds for TA and RA issuance, and therefore the dimensions of the protected airspace around each TCAS-equipped aircraft. The higher the SL, the larger the amount of protected airspace. However, as the amount of protected airspace increases, the incidence of unnecessary alerts has the potential to increase.

TCAS uses two means of determining the operating SL.

1. Pilot Selection. The TCAS Control Panel provides a means for the pilot to select three operating modes:
 - When the Control Panel switch is placed in the Standby Position, TCAS is operating in SL1. In SL1, TCAS does not transmit any interrogations. SL1 is normally selected only when the aircraft is on the ground or if TCAS has failed. The pilot selection

of Standby on the Control Panel is normally the only way that SL1 will be selected.

- When the pilot selects TA-ONLY on the control panel, TCAS is placed into SL2. While in SL2, TCAS performs all surveillance functions and will issue TAs, as required. RAs are inhibited in SL2.
 - When the pilot selects TA-RA or the equivalent mode on the control panel, the TCAS logic automatically selects the appropriate SL based on the altitude of the own aircraft. Table 2 provides the altitude threshold at which TCAS automatically changes SL and the associated SL for that altitude band. In these SLs, TCAS performs all surveillance functions and will issue TAs and RAs, as required
2. Ground-Based Selection. Although the use of ground-based control of SL has not been agreed to between pilots, controllers, and the FAA and is not envisioned for use in U.S. airspace, the capability for ground-based selection of SL is included in the TCAS design. This design feature allows the operating SL to be selected from the ground by using a Mode S uplink message. The TCAS design allows the selection of any SL shown in Table 2 with the exception of SL1.

When the pilot has selected the TA-RA mode on the Control Panel, the operating SL is automatically selected via inputs from the aircraft's radar or pressure altimeter. SL2 will be selected when the TCAS aircraft is below 1,000 feet above ground level (AGL) (± 100 feet) as determined by the radar altimeter input. As previously stated, when in SL2, RAs are inhibited and only TAs will be issued.

In SL3 through SL7, RAs are enabled and issued at the times shown in Table 2. SL3 is set based on inputs from the radar altimeter, while the remaining SLs are set based on

Table 2. Sensitivity Level Definition and Alarm Thresholds

Own Altitude (feet)	SL	Tau (Seconds)		DMOD (nmi)		Altitude Threshold (feet)	
		TA	RA	TA	RA	TA	RA (ALIM)
< 1000	2	20	N/A	0.30	N/A	850	N/A
1000 - 2350	3	25	15	0.33	0.20	850	300
2350 – 5000	4	30	20	0.48	0.35	850	300
5000 – 10000	5	40	25	0.75	0.55	850	350
10000 – 20000	6	45	30	1.00	0.80	850	400
20000 – 42000	7	48	35	1.30	1.10	850	600
> 42000	7	48	35	1.30	1.10	1200	700

pressure altitude using inputs from the own aircraft barometric altimeter.

Tau

TCAS uses time-to-go to CPA, rather than distance, to determine when a TA or an RA should be issued. TCAS uses the time to CPA to determine the range tau and the time to coaltitude to determine the vertical tau. Tau is an approximation of the time, in seconds, to CPA or to the aircraft being at the same altitude. The range tau is equal to the slant range (nmi) divided by the closing speed (knots) multiplied by 3600. The vertical tau is equal to the altitude separation (feet) divided by the combined vertical speed of the two aircraft (feet/minute) times 60.

TCAS II operation is based on the tau concept for all alerting functions. Table 2 provides the TA and RA tau thresholds used in each sensitivity level. The boundary lines shown in Figure 9 indicate the combinations of range and closure rate that would trigger a TA with a 40-second range tau and an RA with a 25-second range tau. This represents the range taus used in SL5. Similar graphs can be generated for other sensitivity levels. Figure 10 shows the combinations of altitude separation and combined vertical speeds that would trigger a

TA with a 40-second vertical tau and an RA with a 25-second vertical tau.

In events where the rate of closure is very low, as shown in Figure 11, an intruder aircraft can come very close in range without crossing the range tau boundaries and thus, without causing a TA or an RA to be issued. To provide protection in these types of advisories, the range tau boundaries are modified as shown in Figure 12. This modification is referred to as DMOD and allows TCAS to use a fixed-range threshold to issue TAs and RAs in these slow closure encounters. The value of DMOD varies with the different sensitivity levels and the values used to issue TAs and RAs are shown in Table 2.

When the combined vertical speed of the TCAS and the intruder aircraft is low, TCAS will use a fixed-altitude threshold to determine whether a TA or an RA should be issued. As with DMOD, the fixed altitude thresholds vary with sensitivity level, and the TA and RA thresholds are shown in Table 2.

For either a TA or an RA to be issued, both the range and vertical criteria, in terms of tau or the fixed thresholds, must be satisfied only one of the criteria is satisfied, TCAS will not issue an advisory.

Protected Volume

A protected volume of airspace surrounds each TCAS-equipped aircraft. The tau and DMOD criteria described above shape the horizontal boundaries of this volume. The vertical tau and the fixed altitude thresholds determine the vertical dimensions of the protected volume.

The horizontal dimensions of the protected airspace are not based on distance, but on tau. Thus, the size of the protected volume depends on the speed and heading of the aircraft involved in the encounter.

TCAS II is designed to provide collision avoidance protection in the case of any two aircraft that are closing horizontally at any rate up to 1200 knots and vertically up to 10,000 feet per minute (fpm).

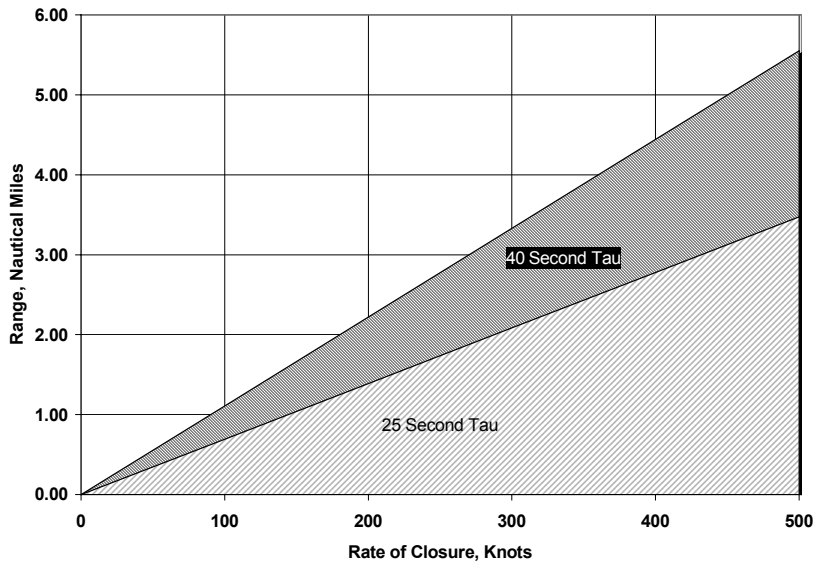


Figure 9. TA/RA Range Tau Values for SL5

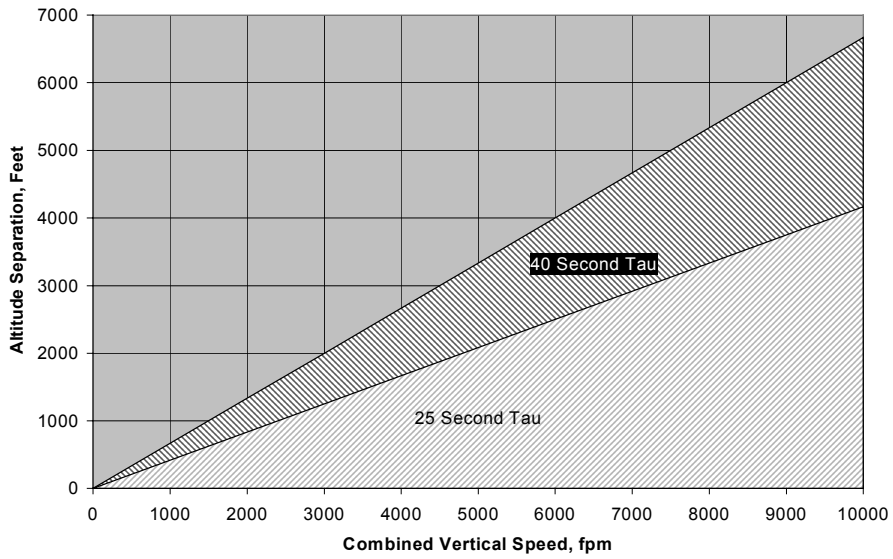


Figure 10. TA/RA Vertical Tau Values for SL5

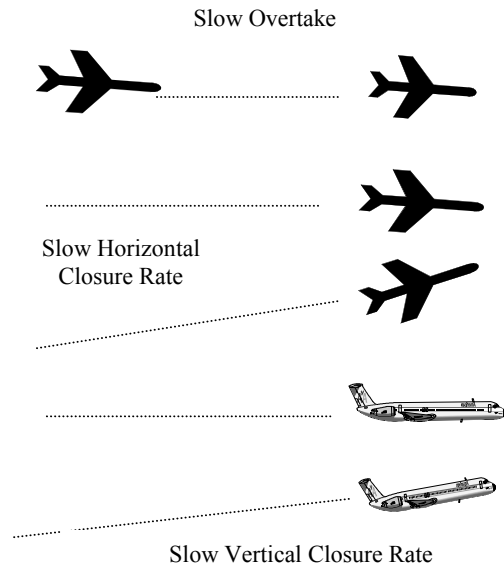


Figure 11. Need for Modified Tau

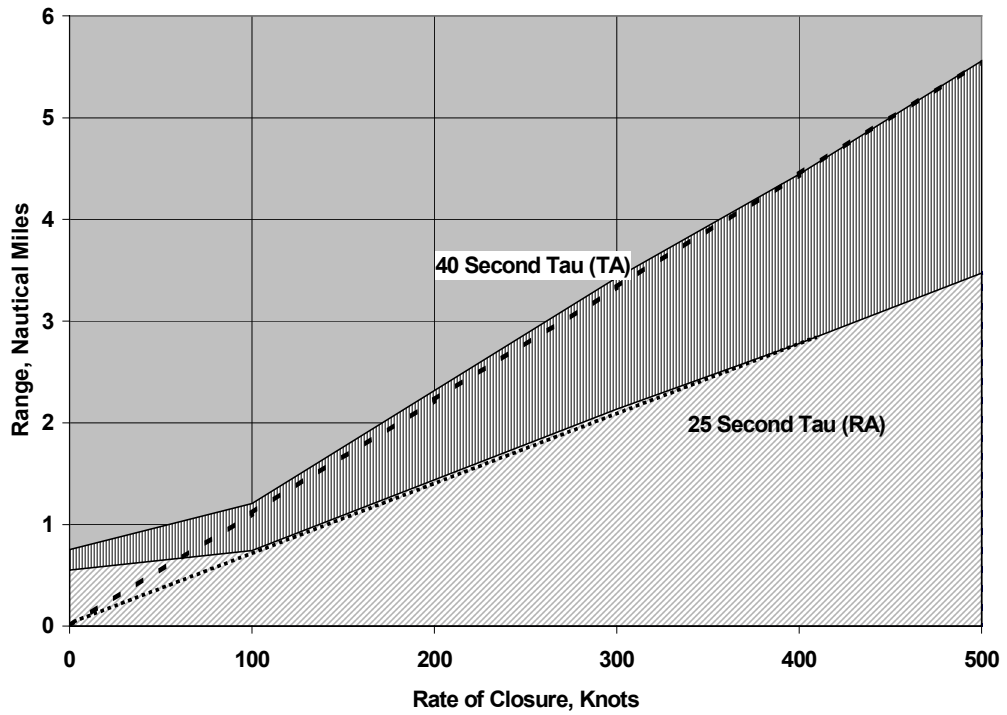


Figure 12. Modified TA/RA Range Tau Values for SL5

CAS Logic Functions

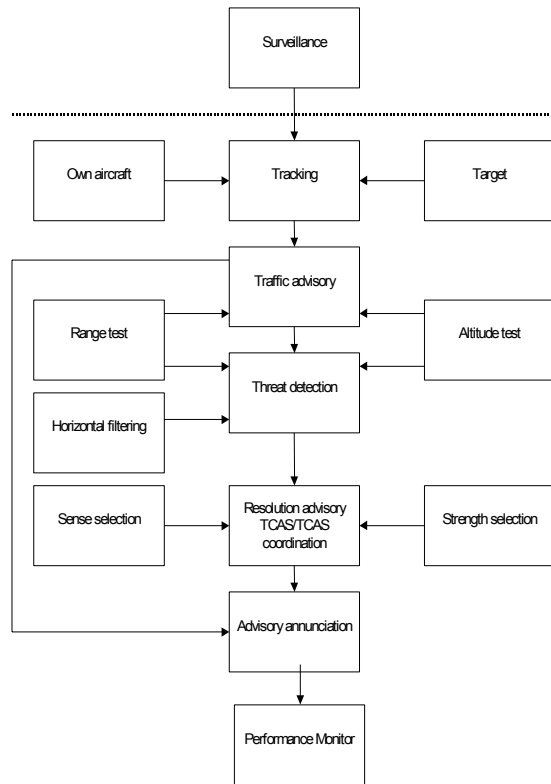


Figure 13. CAS Logic Functions

The logic functions employed by TCAS to perform its collision avoidance function are shown in Figure 13. The following descriptions of these functions are intended to provide a general level of understanding of these functions. The nature of providing an effective collision avoidance system results in the need to have numerous special conditions spread throughout the functions and these are dependent on encounter geometry, range and altitude thresholds, and aircraft performance. These special conditions are beyond the scope of this document. A complete description of the CAS logic and additional details of its design and performance are contained in RTCA DO-185A.

Tracking

Using range, altitude (when available), and bearing from nearby aircraft that are provided to CAS by the Surveillance function, the CAS logic initiates and maintains a three-dimensional track of each aircraft and uses this information to determine the time to CPA and the altitude of each aircraft at CPA. The CAS logic uses the altitude information to estimate the vertical speed of each nearby aircraft and maintains a vertical track for each aircraft. The altitude tracking can use altitude that is quantized in either 100- or 25-foot increments. The CAS tracking function is designed to track aircraft with vertical rates of up to 10,000 fpm.

The CAS logic also uses the data from its own aircraft pressure altitude to determine the own aircraft altitude, vertical speed, and relative altitude of each aircraft. The CAS logic uses the altitude source on the own aircraft that provides the finest resolution. The own aircraft data can be provided in either one, 25-, or 100-foot increments. The outputs from the CAS tracking algorithm, i.e., range, range rate, relative altitude, and vertical rate, are provided to the TA and Threat Detection logic so that the need for a TA or an RA can be determined.

The CAS tracker also uses the difference between its own aircraft pressure altitude and radar altitude to estimate the approximate elevation of the ground above mean sea level. This ground estimation logic functions whenever the own aircraft is below 1750 ft AGL. The ground level estimate is then subtracted from the pressure altitude received from each nearby Mode C-equipped aircraft to determine the approximate altitude of each aircraft above the ground. If this difference is less than 360 feet, TCAS considers the reporting aircraft to be on the ground. If TCAS determines the intruder to be on the ground, it inhibits the generation of advisories against this aircraft.

This methodology is shown graphically in Figure 14.

A Mode S-equipped aircraft is considered to be on the ground if the on-the-ground status bit indicates the aircraft is on the ground.

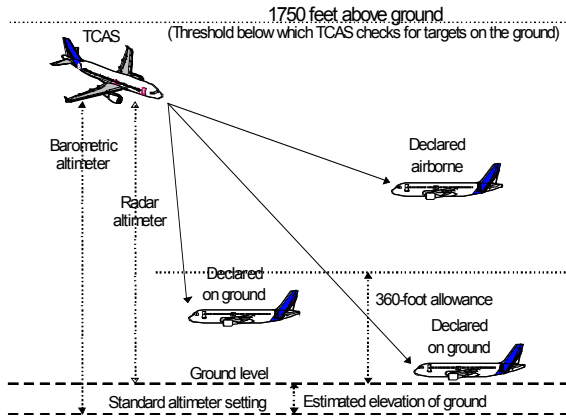


Figure 14. Mode C Target on Ground Determination

Traffic Advisory

Using the tracks for nearby aircraft, range and altitude tests are performed for each altitude-reporting target. Nonaltitude reporting aircraft are assumed to be coaltitude and only range tests are performed on these targets. The range test is based on tau, and the TA tau must be less than the threshold shown in Table 2. In addition, the current or projected vertical separation at CPA must be within the TA altitude threshold shown in Table 2 for a target to be declared an intruder. If the TA logic declares an aircraft to be an intruder, a TA will be issued against that aircraft.

A nonaltitude reporting aircraft will be declared an intruder if the range test alone shows that the calculated tau is within the RA tau threshold associated with the current SL being used as shown in Table 2.

Version 7 includes changes to ensure that a target's TA status is maintained in slow closure rate encounters by invoking more stringent requirements for removing a TA.

These changes address problems reported in which multiple TAs were issued against the same target in parallel approach encounters and in RVSM airspace.

Threat Detection

Range and altitude tests are performed on each altitude-reporting intruder. If the RA tau and either the time to co-altitude or relative altitude criteria associated with the current SL are met, the intruder is declared a threat. Depending on the geometry of the encounter and the quality and age of the vertical track data, an RA may be delayed or not selected at all. RAs cannot be generated for nonaltitude reporting intruders.

Version 7 includes changes in the Threat Detection logic to improve the performance of this portion of the logic. These changes include the following:

- Declaring the own aircraft to be on the ground when the input from the radar altimeter is valid and below 50 feet AGL. This precludes complete reliance on the own aircraft's weight-on-wheels switch that has been shown to be unreliable in some aircraft.
- Preventing the SL from decreasing during a coordinated encounter to maintain the continuity of a displayed RA, and thus prevent multiple RAs from being issued against the same intruder.
- Inhibiting threat declaration against intruder aircraft with vertical rates in excess of 10,000 fpm.
- Reducing alert thresholds to account for the reduction in vertical separation to 1000 feet above FL290 in RVSM airspace.
- Modifying the criteria used to reduce the frequency of bump-up or high vertical rate encounters. This modification allows a level aircraft to delay the issuance of an RA for up to five seconds to allow additional time

for detecting a level-off maneuver by a climbing or descending aircraft.

- Introducing a horizontal miss distance (HMD) filter to reduce the number of RAs against intruder aircraft having a large horizontal separation at CPA. The HMD filter can also weaken an RA prior to ALIM being obtained to minimize altitude displacement when the filter is confident that the horizontal separation at CPA will be large.

Resolution Advisory Selection

When an intruder is declared a threat, a two step process is used to select the appropriate RA for the encounter geometry. The first step in the process is to select the RA sense, i.e., upward or downward. Based on the range and altitude tracks of the intruder, the CAS logic models the intruder's flight path from its present position to CPA. The CAS logic then models upward and downward sense RAs for own aircraft, as shown in Figure 15, to determine which sense provides the most vertical separation at CPA. In the encounter shown in Figure 15, the downward sense logic will be selected because it provides greater vertical separation.

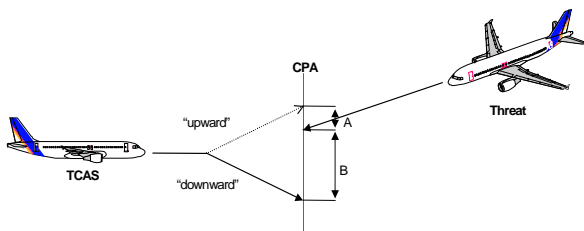


Figure 15. RA Sense Selection

In encounters where either of the senses results in the TCAS aircraft crossing through the intruder's altitude, TCAS is designed to select the nonaltitude crossing sense if the noncrossing sense provides the desired vertical separation, known as ALIM, at CPA. The value of ALIM varies with SL and the value for each SL is shown in

Table 2. If the nonaltitude crossing sense provides at least ALIM feet of separation at CPA, this sense will be selected even if the altitude-crossing sense provides greater separation. If ALIM cannot be obtained in the nonaltitude crossing sense, an altitude crossing RA will be issued. Figure 16 shows an example of encounters in which the altitude crossing and nonaltitude crossing RA senses are modeled and the noncrossing RA sense is selected.

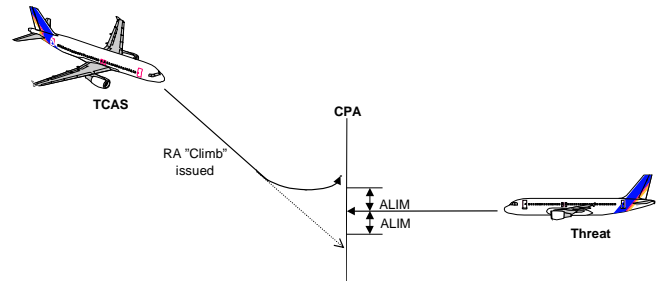


Figure 16. Selection of Noncrossing RA Sense

The second step in selecting an RA is to choose the strength of the advisory. TCAS is designed to select the RA strength that is the least disruptive to the existing flight path, while still providing ALIM feet of separation. Table 3 provides a list of possible advisories that can be issued as the initial RA when only a single intruder is involved in the encounter. After the initial RA is selected, the CAS logic continuously monitors the vertical separation that will be provided at CPA and if necessary, the initial RA will be modified.

A new feature was implemented in Version 7 to reduce the frequency of RAs that reverse the existing vertical rate of the own aircraft. When two TCAS-equipped aircraft are converging vertically with opposite rates and are currently well separated in altitude, TCAS will first issue a vertical speed limit (Negative) RA to reinforce the pilots' likely intention to level off at adjacent flight levels. If no response to this initial RA is detected, or if either aircraft accelerates toward the other aircraft,

the initial RA will strengthen as required. This change was implemented to reduce the frequency of initial RAs that reversed the vertical rate of the own aircraft (e.g., posted a climb RA for a descending aircraft) because pilots did not follow a majority of these RAs, and those that were followed, were considered to be disruptive by controllers.

In some events, the intruder aircraft will maneuver vertically in a manner that thwarts the effectiveness of the issued RA. In these cases, the initial RA will be modified to either increase the strength or reverse the sense of the initial RA. The RA issued when an increased strength RA is required is dependent on the initial RA that was issued. Figure 17 depicts an encounter where it is necessary to increase the climb rate from the 1500 fpm required by the initial RA to 2500 fpm. This is an example of an Increase Climb RA. Figure 18 depicts an encounter where an initial Descend RA requires reversal to a Climb RA after the intruder maneuvers.

In a coordinated encounter in which an aircraft appears to ignore an initial nonaltitude crossing RA, Version 7 will inhibit Increase Rate RAs for this aircraft and only consider RA reversals if the other aircraft maneuvers.

Version 7 permits sense reversals in coordinated encounters. This sense reversal logic is very similar to that previously available in encounters with non-TCAS threats. In TCAS-TCAS encounters, RA reversals are not permitted for the first nine seconds after the initial RA to allow time for both aircraft to initiate their RA response. RA reversals are not permitted if the aircraft are within 300 feet of each other and the reversal would result in an altitude crossing RA. In coordinated encounters, the logic that considers issuing an Increase Rate RA late in an altitude crossing RA is disabled.

Because of aircraft climb performance limitations at high altitude or in some flap

and landing gear configurations, an aircraft installation may be configured to inhibit Climb or Increase Climb RA under some conditions. These inhibit conditions can be provided via program pins in the TCAS connector or in real-time via an input from a Flight Management System (FMS). If these RAs are inhibited, the RA Selection Criteria will not consider them in the RA selection and will choose an alternative upward sense RA if the downward sense RA does not provide adequate vertical separation.

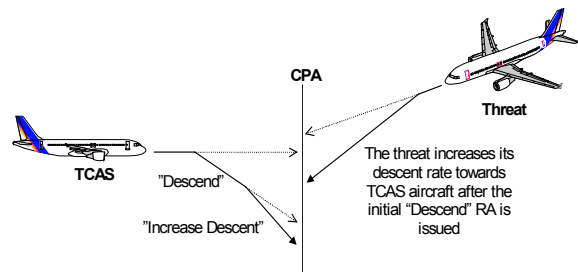


Figure 17. Increase Rate RA

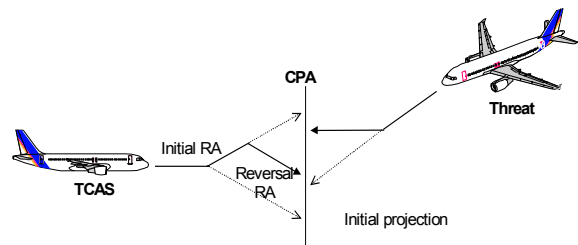


Figure 18. RA Reversal

TCAS is designed to handle multi-aircraft encounters, i.e., those encounters in which more than one intruder is detected at the same time. (It should be noted that in more than 10 years of TCAS operation, less than a half dozen true multi-aircraft encounters have been recorded worldwide.) TCAS will attempt to resolve these types of encounters by selecting a single RA that will provide adequate separation from each of the intruders. This RA can be any of the initial RAs shown in Table 3, or a combination of upward and downward sense RAs, e.g., Do Not Climb and Do Not Descend. It is

Table 3. Possible Initial RAs

RA TYPE	UPWARD SENSE		DOWNWARD SENSE	
	RA	Required Vertical Rate	RA	Required Vertical Rate
Positive	Climb	1500 to 2000 fpm	Descend	-1500 to -2000 fpm
Positive	Crossing Climb	1500 to 2000 fpm	Crossing Descend	-1500 to -2000 fpm
Positive	Maintain Climb	1500 to 4400 fpm	Maintain Descend	-1500 to -4400 fpm
Negative	Do Not Descend	> 0 fpm	Do Not Climb	< 0 fpm
Negative	Do Not Descend > 500 fpm	> -500 fpm	Do Not Climb > 500 fpm	< + 500 fpm
Negative	Do Not Descend > 1000 fpm	> -1000 fpm	Do Not Climb > 1000 fpm	< + 1000 fpm
Negative	Do Not Descend > 2000 fpm	> -2000 fpm	Do Not Climb > 2000 fpm	< + 2000 fpm

possible that the RA selected in such encounters may not provide ALIM separation from all intruders. Version 7 provides new capabilities to the multi-aircraft logic to allow this logic to utilize Increase Rate RAs and RA Reversals to better resolve encounters.

During an RA, if the CAS logic determines that the response to a Positive RA (see Table 3) has provided ALIM feet of vertical separation before CPA, the initial RA will be weakened to either a Do Not Descend RA (after an initial Climb RA) or a Do Not Climb RA (after an initial Descend RA). This is done to minimize the displacement from the TCAS aircraft's original altitude. Negative RAs will not be weakened and the initial RA will be retained until CPA unless it is necessary to strengthen the RA or reverse the RA sense.

TCAS is designed to inhibit Increase Descent RAs below 1450 feet AGL; Descend RAs below 1100 feet AGL; and all RAs below 1000±100 feet AGL. If a Descend RA is being displayed as the own aircraft descends through 1100 feet AGL, the RA will be modified to a Do Not Climb RA.

After CPA is passed and the range between the TCAS aircraft and threat aircraft begins to increase, all RAs are cancelled.

TCAS/TCAS Coordination

In a TCAS/TCAS encounter, each aircraft transmits interrogations to the other via the Mode S link to ensure the selection of complementary RAs by the two aircraft. The coordination interrogations use the same 1030/1090 MHz channels used for surveillance interrogations and replies and are transmitted once per second by each aircraft for the duration of the RA. Coordination interrogations contain information about an aircraft's intended RA sense to resolve the encounter with the other TCAS-equipped intruder. The information in the coordination interrogation is expressed in the form of a complement. For example, when an aircraft selects an upward sense RA, it will transmit a coordination interrogation to the other aircraft that restricts that aircraft's RA selection to those in the downward sense. The strength of the downward sense RA would be determined by the threat aircraft based on the encounter geometry and the RA Selection logic.

The basic rule for sense selection in a TCAS/TCAS encounter is that each TCAS must check to see if it has received an intent message from the other aircraft before selecting an RA sense. If an intent message has been received, TCAS selects the opposite sense from that selected by the other aircraft and communicated via the coordination interrogation. If TCAS has not received an intent message, the sense is selected based on the encounter geometry in the same manner as would be done if the intruder were not TCAS equipped.

In a majority of the TCAS/TCAS encounters, the two aircraft will declare the other aircraft to be a threat at slightly different times. In these events, coordination proceeds in a straightforward manner with the first aircraft declaring the other to be a threat, selecting its RA sense based on the encounter geometry, and transmitting its intent to the other aircraft. At a later time, the second aircraft will declare the other aircraft to be a threat, and having already received an intent from the first aircraft, will select a complementary RA sense. The complementary sense that is selected will then be transmitted to the other aircraft in a coordination interrogation.

Occasionally, the two aircraft declare each other as threats simultaneously, and therefore, both aircraft will select their RA sense based on the encounter geometry. In these encounters, there is a chance that both aircraft will select the same sense. When this happens, the aircraft with the higher Mode S address will detect the selection of the same sense and will reverse its sense.

Version 7 includes the capability for TCAS to issue RA reversals in coordinated encounters if the encounter geometry changes after the initial RA is issued. The RA reversals in coordinated encounters are

announced to the pilot in the same way as RA reversals against non-TCAS intruders. In a coordinated encounter, if the aircraft with the low Mode S address has Version 7 installed, the low Mode S address can reverse the sense of its initial RA and communicate this to the high Mode S address aircraft. The high Mode S address aircraft will then reverse its displayed RA. The aircraft with the high Mode S address can be equipped with either Version 6.04 or Version 7.

In a coordinated encounter, only one RA reversal based on changes in the encounter geometry can be issued. The initial RA sense will not be reversed until it has been displayed for at least nine seconds, unless the low Mode S address aircraft has a vertical rate higher than 2500 feet per minute and acts contrary to the RA. This delay is included in the design to allow sufficient time for the two aircraft to initiate a response to the initial RA.

Advisory Annunciation

The CAS logic also performs the function of setting flags that control the displays and aural annunciations. The traffic display, the RA display, and the aural devices use these flags to alert the pilot to the presence of TAs and RAs. Aural annunciations are inhibited below 500±100 feet AGL.

The TCAS aural annunciations are integrated with other environmental aural alerts available on the aircraft. The priority scheme established for these aural alerts gives windshear detection systems and ground proximity warning systems (GPWS) a higher annunciation priority than a TCAS alert. TCAS aural annunciations will be inhibited during the time that a windshear or GPWS alert is active.

Air/Ground Communications

Using the Mode S data link, TCAS can downlink RA reports to Mode S ground sites. These reports can be provided in the Mode S transponder's 1090 MHz response to an interrogation from the Mode S ground sensor requesting information and it can also be provided automatically using the TCAS 1030 MHz transmitter.

During the time an RA is displayed, TCAS will automatically generate a downlink message containing information on the RA being displayed to the crew. This information, known as the RA Broadcast, is provided when an RA is initially issued and when the RA is updated. It is rebroadcast every eight seconds using the TCAS 1030 MHz transmitter. At the end of an RA, an indication will be provided to the ground that the RA is no longer being displayed.

Traffic Advisory Display

The functions of the traffic advisory display are to aid the flight crew in visually acquiring intruder aircraft; discriminating between intruder aircraft and other nearby aircraft; determining the horizontal position of nearby aircraft; and providing confidence in the performance of TCAS.

Traffic advisory displays have been implemented in a number of different ways and with varying levels of flexibility. The requirements for the various means of implementing the traffic displays are documented in RTCA DO-185A. An overview of the traffic display features and capabilities was provided earlier in this booklet.

Version 7 requirements inhibit the display of intruders with relative altitudes of more than ± 9900 feet if the pilot has selected the display of relative altitude. This display range is the maximum possible because only two digits are available to display the relative altitude.

Resolution Advisory Displays

The RA display is used by TCAS to advise the pilot how to maneuver, or not maneuver in some cases, to resolve the encounter as determined by the CAS logic. Examples for various RA display implementations are shown in Figure 3 and Figure 4. The requirements for RA displays are contained in RTCA DO-185A.

To accommodate physical limitations on some IVSI displays, Version 7 will not allow the display of any Maintain Rate RAs that call for vertical rates in excess of 4400 fpm. Because of this, the logic will model the minimum of the own aircraft's vertical rate and 4400 fpm if a Maintain Rate RA is required; and will select the sense that provides the best separation, even if the selected sense is opposite the existing vertical speed.

Aural Annunciations

Whenever the collision avoidance logic issues a TA or an RA, a voice alert is issued to ensure that the pilots are aware of the information being displayed on the traffic and RA displays. These aural annunciations can be provided via a dedicated speaker installed in the cockpit or via the aircraft's audio panels so that they are heard in the pilots' headsets. Table 4 provides a listing of the aural annunciations that are used by TCAS in Version 7, as well as those used in existing implementations. The changes incorporated in Version 7 are highlighted.

Performance Monitoring

TCAS is equipped with performance monitoring software that continuously and automatically monitors the health and performance of TCAS. The performance monitoring operates whenever power is applied to TCAS. In addition, the performance monitor includes a pilot-initiated test feature that includes expanded

tests of the TCAS displays and aural annunciations. The performance monitor also supports expanded maintenance diagnostics that are available to maintenance and engineering personnel while the aircraft is on the ground.

The performance monitor validates many of the inputs received from other aircraft systems and validates the performance of the TCAS processor. These include the own aircraft pressure altitude input and the connection of TCAS to the aircraft suppression bus.

When the performance monitor detects anomalous performance within TCAS or an invalid input from a required on-board system, the failure is annunciated to the pilot. If appropriate, all or a portion of the TCAS functions may be disabled or inhibited. If the performance monitor disables any TCAS capability, it will continue to monitor the remaining functions and if the detected failure is removed, the full operational capability will be restored.

Table 4. TCAS Aural Annunciations

TCAS Advisory	Version 7 Aural Annunciation	Existing Aural Annunciation
Traffic Advisory	Traffic, Traffic	Traffic, Traffic
Climb RA	Climb, Climb	Climb, Climb, Climb
Descend RA	Descend, Descend	Descend, Descend, Descend
Altitude Crossing Climb RA	Climb, Crossing Climb; Climb, Crossing Climb	Climb, Crossing Climb; Climb, Crossing Climb
Altitude Crossing Descend RA	Descend, Crossing Descend; Descend, Crossing Descend	Descend, Crossing Descend; Descend, Crossing Descend
Reduce Climb RA	Adjust Vertical Speed, Adjust	Reduce Climb, Reduce Climb
Reduce Descent RA	Adjust Vertical Speed, Adjust	Reduce Descent, Reduce Descent
RA Reversal to a Climb RA	Climb, Climb, NOW; Climb, Climb NOW	Climb, Climb, NOW; Climb, Climb NOW
RA Reversal to a Descend RA	Descend, Descend NOW; Descend, Descend NOW	Descend, Descend NOW; Descend, Descend NOW
Increase Climb RA	Increase Climb, Increase Climb	Increase Climb, Increase Climb
Increase Descent RA	Increase Descent, Increase Descent	Increase Descent, Increase Descent
Maintain Rate RA	Maintain Vertical Speed, Maintain	Monitor Vertical Speed
Altitude Crossing, Maintain Rate RA (Climb and Descend)	Maintain Vertical Speed, Crossing Maintain	Monitor Vertical Speed
Weakening of Initial RA	Adjust Vertical Speed, Adjust	Monitor Vertical Speed
Preventive RA (No change in vertical speed required)	Monitor Vertical Speed	Monitor Vertical Speed, Monitor Vertical Speed
RA Removed	Clear of Conflict	Clear of Conflict

Use of TCAS

The operational use TCAS II throughout the world during the last 10 years has demonstrated the efficiency of TCAS II as an airborne collision avoidance system. During this time period, the procedures for the use of TCAS II have been developed and refined to ensure that the operation of TCAS provides aircraft with effective collision avoidance protection without having unnecessary affects on the controllers responsible for separating aircraft. These operating practices and procedures are now included within FAA, ICAO, and other countries' regulations and provide the basis for the practical training of pilots and controllers.

Regulations and Operational Guidance

Within the U.S., the guidance on the operational use of TCAS is contained in Advisory Circular (AC) 20-155. This AC provides guidelines for developing flight crew training programs, procedures for responding to an RA, a list of good operating practices, sample forms for providing inputs on the performance of TCAS, and suggested phraseology to be used when advising controllers of an RA event.

Information similar to that contained in AC 20-155 has been included in ICAO Annexes and other documentation. Individual countries have used the information contained in the ICAO documentation to develop and promulgate their own requirements and procedures.

The guidance regarding TCAS operation for controllers is contained in the ATC Controllers Handbook (Order 7110.65) and in various policy letters issued by FAA Headquarters.

Controllers Responsibilities

The controller's responsibilities during a TCAS RA are defined in FAA Order 7110.65 and are repeated below.

When an aircraft under your control jurisdiction informs you that it is responding to a TCAS RA, do not issue control instructions that are contrary to the RA the crew has advised you that they are executing. Provide safety alerts regarding terrain or obstructions and traffic advisories for the aircraft responding to the RA and all other aircraft under your control jurisdiction, as appropriate.

Unless advised by other aircraft that they are also responding to a TCAS RA, do not assume that other aircraft in the proximity of the responding aircraft are involved in the RA maneuver or are aware of the responding aircraft's intended maneuvers. Continue to provide control instructions, safety alerts, and traffic advisories as appropriate to such aircraft.

When the responding aircraft has begun a maneuver in response to an RA, the controller is not responsible for providing standard separation between the aircraft that is responding to an RA and any other aircraft, airspace, terrain, or obstructions. Responsibility for standard separation resumes when one of the following conditions is met:

1. The responding aircraft has returned to its assigned altitude.
2. The flightcrew informs you that the TCAS maneuver is completed and you observe that standard separation has been reestablished.
3. The responding aircraft has executed an alternate clearance and you observe that standard separation has been reestablished.

FAA Order 7110.65 also references AC 120-55 to provide information on the suggested phraseology to be used by pilots to notify the controller about a TCAS event. The suggested phraseology is discussed in the following section, *Pilot Responsibilities*.

Pilot Responsibilities

In general terms, the following procedures and practices have been developed regarding the pilots responsibilities and actions while using TCAS. These procedures and practices have been extracted from AC 20-155.

Respond to TAs by attempting to establish visual contact with the intruder aircraft and other aircraft that may be in the vicinity. Coordinate to the degree possible with other crewmembers to assist in searching for traffic. Do not deviate from an assigned clearance based only on TA information. For any traffic that is acquired visually, continue to maintain or attain safe separation in accordance with current Federal Aviation Regulations (FAR) and good operating practices.

When an RA occurs, the pilot flying should respond immediately by direct attention to RA displays and maneuver as indicated unless doing so would jeopardize the safe operation of the flight or unless in the approach environment the flight crew can assure separation with the help of definitive visual acquisition of the aircraft causing the RA. By not responding to an RA, the flightcrew effectively takes responsibility for achieving safe separation.

Satisfy RAs by disconnecting the autopilot, using prompt, positive control inputs in the direction and with the magnitude TCAS advises. To achieve the required vertical rate (normally 1,500 fpm climb or descent), first adjust the aircraft’s pitch using the suggested guidelines shown in Table 5.

Table 5. Suggested Pitch Adjustment Required to Comply with TCAS RA

Speed	Pitch Adjustment
.80 Mach	2 degrees
250 Knots Indicated Airspeed (KIAS) Below 10,000 feet	4 degrees
Below 200 KIAS	5 to 7 degrees

Then refer to the vertical speed indicator and make necessary pitch adjustments to place the vertical speed indicator in the green arc of the RA display. On aircraft with pitch guidance TCAS RA displays, follow the RA pitch command for initial, increase, and weakening RAs.

Excursions from assigned altitude, when responding to an RA, typically should be no more than 300 to 500 feet to satisfy the conflict. Vertical speed responses should be made to avoid red arcs or outlined pitch avoidance areas, and, if applicable, to accurately fly to the green arc or outlined pitch guidance area.

Respond immediately to any increase or reversal RA maneuver advisories. Initial vertical speed response to an increase or reversal RA is expected by TCAS, using 1/3 g acceleration, within 2-1/2 seconds after issuance of the advisory. Again, avoid red arcs or outlined pitch avoidance areas and fly to the green arc or outlined pitch guidance area.

If an initial corrective RA is downgraded or weakened (for example, a Climb RA downgrades to a Do Not Descend RA), pilots should respond to the weakening RA and adjust the aircraft's vertical speed accordingly but still keep the needle or pitch guidance symbol out of the red arc or outlined pitch avoidance area. Pilots are reminded that attention to the RA display and prompt reaction to the weakened RA will minimize altitude excursions and potential disruptions to ATC. This will

allow for proper TCAS-to-TCAS resolution of encounters and reduce the probability of additional RAs against the intruder or other traffic.

In some instances, it may not be possible to respond to a TCAS RA and continue to satisfy a clearance at the same time. Even if a TCAS RA maneuver is inconsistent with the current clearance, respond appropriately to the RA. Because TCAS tracks all transponder-equipped aircraft in the vicinity, responding to an RA for an intruder assures a safe avoidance maneuver from that intruder and from other Mode C-equipped aircraft.

If a TCAS RA response requires deviation from an ATC clearance, expeditiously return to the current ATC clearance when the traffic conflict is resolved or the TCAS message “Clear of Conflict” is heard, or follow any subsequent change to clearance as advised by ATC. In responding to a TCAS RA that directs a deviation from assigned altitude, communicate with ATC as soon as practicable after responding to the RA. When the RA is cleared, the flight crew should advise ATC that they are returning to their previously assigned clearance or should acknowledge any amended clearance issued.

Unless approved by the Administrator, pilots are expected to operate TCAS while in-flight in all airspace, including oceanic, international, and foreign airspace.

TCAS does not alter or diminish the pilot's basic authority and responsibility to ensure safe flight. Because TCAS does not respond to aircraft that are not transponder-equipped or aircraft with a transponder failure, TCAS alone does not ensure safe separation in every case. Further, TCAS RAs may, in some cases, conflict with flight path requirements because of terrain, such as an obstacle limited climb segment or an approach to rising terrain. Because many approved instrument procedures and

Instrument Flight Rules (IFR) clearances are predicated on avoiding high terrain or obstacles, it is particularly important that pilots maintain situational awareness and continue to use good operating practices and judgment when following TCAS RAs. Maintain frequent outside visual scan, use see and avoid vigilance, and continue to communicate as needed and as appropriate with ATC.

The pilot is to inform the controller about the RA deviation as soon as possible. The phraseology, to be used by pilots, is shown in Table 6. The phraseology was developed by ICAO and has been published in PANS-RAC. The FAA has incorporated these recommendations into AC 20-155.

Table 6. Recommended Phraseology for Reporting RAs

Situation	Phraseology
Responding to an RA	“TCAS Climb” or “TCAS Descend”
Initial RA report issued after RA is completed	“TCAS Climb (or descent), returning to [assigned clearance]”
Initial RA report issued after returning to assigned clearance	“TCAS Climb (or descent) completed, [assigned clearance] resumed”
Unable to follow a newly issued clearance because of an RA	“Unable to comply, TCAS resolution advisory”
Controller acknowledgement of any TCAS report	No specific phraseology is defined

The phraseology shown in Table 6 is suggested and should contain: (1) name of the ATC facility, (2) aircraft identification (ID), and (3) nature of the TCAS deviation. When a flight crew receives a TCAS RA to either climb or descend from their assigned altitude, or the RA otherwise affects their ATC clearance or their pending maneuver or

maneuver in progress, the crew should inform ATC when beginning the excursion from clearance or as soon as workload allows in the following manner: “XYZ Center, (Aircraft ID), TCAS Climb/Descent.”

Following such a communication, the designated air traffic facility is not required to provide approved standard separation to the TCAS maneuvering aircraft until the TCAS encounter is cleared and standard ATC separation is achieved. If workload permits, traffic information may be provided by the controller in accordance with FAA Order 7110.65.

When the RA is clear, the flight crew should advise ATC that they are returning to their previously assigned clearance or subsequent amended clearance. When the deviating aircraft has renegotiated its clearance with ATC, the designated air traffic facility is expected to resume providing appropriate separation services in accordance with FAA Order 7110.65.

NOTE: Communication is not required if the pilot is able to satisfy the RA guidance and maintain the appropriate ATC clearance.

Operational Experience

The evaluation of TCAS II performance during its implementation has demonstrated that this equipment provides an overall improvement in flight safety. In reportedly dangerous situations, TAs have made visual acquisition of intruders possible in sufficient time to avoid any risk of collision. In some events, RAs have been issued that are believed to have prevented critical near midair collisions and midair collisions from taking place.

However, the operational experience has indicated that some issues related to TCAS continue to occur. These issues include the following.

Pilots sometimes deviate significantly further from their original clearance than was required or desired while complying with an RA. Data and simulator trials have shown that pilots often are not aware of the RA being weakened and many pilots do not want to begin maneuvering back toward their original clearance until the RA is over. To reduce the frequency of the large altitude displacements while responding to an RA, Version 7 introduces new aural annunciations to accompany the weakening RAs and provides a target vertical speed on the RA display for the weakened RA. In addition, the CAS logic has been modified to provide only one type of weakened RA and that RA is either a Do Not Climb or Do Not Descend RA. This results in the weakened RA always calling for the aircraft to be leveled after ALIM feet of separation have been obtained.

Pilots are often slow in reporting the initial deviation to the controller and this resulted in situations where the controller was issuing clearances that were in the opposite sense than that directed by the RA. The standard ICAO phraseology is sometimes not used and at times, the controller does not understand the initial RA notification from the pilot. In some events, this resulted in distracting dialogue between the pilot and controller regarding the RA.

Some pilots request information, or refuse a clearance, based upon information shown on the traffic display. These practices are not encouraged because they can cause added congestion on the radio channel and may result in higher controller and pilot workloads. This improper use of the traffic display has been addressed via pilot training programs.

Aircraft have also been observed making horizontal maneuvers based solely on the information shown on the traffic display, without visual acquisition by the aircrew. Such maneuvers may cause a significant degradation in the level of flight safety and are contrary to a limitation contained in the TCAS Airplane Flight Manual Supplement.

Event reports also indicate that some pilots have not reacted to RAs, when they have traffic information from the controller, but have not visually acquired the intruder. This is a potentially hazardous situation if the ground radar is not tracking the intruder causing the RA. In addition, if the intruder is also TCAS-equipped, the RAs will be coordinated, and a nonresponse by one aircraft will result in the other aircraft having to maneuver further to resolve the RA.

An RA is generally unexpected by a controller and in a majority of the cases is a disruption to his or her workload. This disruption is due to an aircraft's unexpected deviation from the ATC clearance, the subsequent discussion regarding the RA on the active frequency, and the possibility of an induced conflict with a third aircraft. Although the latter concern is understandable, many controllers do not understand the multi-aircraft logic that is provided by TCAS so that the initial RA can be modified if the response does result in a conflict with a third aircraft.

Operational experience has shown that the unexpected interactions between TCAS and the ATC systems can occur under the following conditions.

Aircraft leveling off at 1,000 ft above or below conflicting traffic that is level may result in RAs being issued to the level aircraft. These RAs are triggered because the climbing or descending aircraft maintains high vertical speeds when approaching the cleared altitude or flight level. The CAS logic contains algorithms that will recognize this encounter geometry and will delay the issuance of the RA to the level aircraft by up to five seconds to allow TCAS to detect the initiation of the

level-off maneuver by the intruder. A previous version of the logic included these algorithms at lower altitudes, and these have been effective in reducing the frequency of this type of RA. Version 7 expands the use of this logic to higher altitudes to address the occurrence of these types of RAs in the en route airspace structure.

Altitude crossing clearances issued by a controller based on maintaining visual separation may result in RAs being issued, particularly if one of the aircraft is level

Advisories issued against some categories of aircraft, e.g., aircraft operating under visual flight rules (VFR), **high performance military aircraft during high g maneuvers, and helicopters operating in the immediate vicinity of the airport.** Although minor modifications have been made to TCAS to address these types of RAs, these problems are related as much to the airspace management, in general, as to the function of TCAS II.

Training Programs

Many of the operational issues identified during the initial operations of TCAS can be traced to misunderstandings regarding the operation of TCAS, its capabilities, and its limitations. For these reasons, it is essential that all pilots operating the system be trained in how to use the system and that all controllers receive training on how TCAS operates, how pilots are expected to use the systems, and the potential interactions between TCAS and the ATC system.

The FAA and the industry have worked together to develop and refine training guidelines for both pilots and controllers. AC 120-55 contains guidance for the development and implementation of pilot training programs. While this AC is not

directly applicable to operators that are governed by Part 91 and Part 135 of the Federal Aviation Regulations, the training guidelines contained in the AC should be followed by these operators.

The FAA has also developed and distributed a controller training program to all of its ATC facilities.

ICAO has developed guidelines for both pilot and controller training programs, and this information has been distributed to all ICAO member countries.

Pilot Training Programs

Experience has shown that it is essential that crews operating TCAS-equipped aircraft complete an approved pilot-training course. The proper use of TCAS II by pilots is required to ensure the proper integration of TCAS into the air traffic control environment and the realization of the expected improvements in flight safety. Pilot training should include two complementary parts as defined below.

Theory. Pilots should have an understanding of how TCAS works. This includes an understanding of the alert thresholds, expected response to TAs and

RAs, proper use of TCAS-displayed information, phraseology, and system limitations. This training is generally accomplished in a classroom environment.

Simulator practice. The response to an RA requires prompt and appropriate reactions from the aircrews involved. Therefore, it is necessary to include RA events in the routine flight simulator training exercises, so that pilots can experience the circumstances surrounding an RA in a realistic environment. When the inclusion of TCAS into simulator training programs is not possible, the FAA has approved the use of other interactive training devices to supplement the classroom training.

Controller Training Programs

While controllers do not use TCAS II, they need to be aware of its presence, capabilities, and limitations while performing their responsibilities. The controller training should be similar to the classroom training provided to pilots, but supplemented with material that demonstrates advisories that have had both positive and negative impacts on the control and traffic situation.

SUMMARY

TCAS is a last resort tool designed to prevent midair collisions between aircraft. Operational experience has demonstrated the utility and efficiency of TCAS. At the same time, operation of TCAS has identified areas in which the design and algorithms needed refinement or improvement to further enhance the efficiency of TCAS and its interaction with the controllers and the ATC system. As a result, the aviation industry has worked to develop, test, certify, and implement TCAS Version 7. Version 7 is now being introduced into service worldwide. The technical features of the system provide a significant improvement in flight safety, and this has now attained universal recognition in the world of aviation. Many countries have mandated the carriage of TCAS II, and ICAO has proposed a worldwide mandate of TCAS II Version 7 by 2003.

However, one must be aware that TCAS is not a perfect system. TCAS cannot preclude all collision risks and the system may, marginally, induce an additional risk. Consequently, it is essential that ATC procedures are designed to provide flight safety without any reliance upon the use of TCAS and that both pilots and controllers are well versed in the operational capabilities and limitations of TCAS.

For more information on TCAS and the capabilities and requirements for Version 7, contact the Aircraft Certification Office, AIR-130, 800 Independence Avenue, S.W., Washington, D.C. 20591.

ABBREVIATIONS

ACAS	Airborne Collision Avoidance System
ACO	Aircraft Certification Office
ADC	Air Data Computer
AEEC	Airline Electronic Engineering Committee
AGL	Above Ground Level
AIC	Aeronautical Information Circular
ALIM	Altitude Limit
ATCRBS	Air Traffic Control Radar Beacon System
BCAS	Beacon Collision Avoidance System
CAA	Civil Aviation Authority
CAS	Collision Avoidance System
CPA	Closest Point of Approach
DMOD	Distance MODification
DME	Distance Measuring Equipment
DMTL	Dynamic Minimum Triggering Level
EATCHIP	European Air Traffic Control Harmonization and Integration Program
EFIS	Electronic Flight Instrument System
EICAS	Engine Indication and Crew Alerting System
FAA	Federal Aviation Administration
FL	Flight Level
FMS	Flight Management System
FRUIT	False Replies from Unsynchronized Interrogator Transmissions
ft	feet
fpm	feet per minute
GPWS	Ground Proximity Warning System
HMD	Horizontal Miss Distance
HUD	Heads Up Display
ICAO	International Civil Aviation Organization
IFR	Instrument Flight Rules
IVSI	Instantaneous Vertical Speed Indicator
JCAB	Japan Civil Aviation Bureau
KIAS	Knots Indicated Airspeed
LCD	Liquid Crystal Display

LED	Light Emitting Diode
MDF	Miss Distance Filtering
MHz	Megahertz
MOPS	Minimum Operational Performance Standards
MTL	Minimum Triggering Level
NAS	National Airspace System
ND	Navigation Display
NMAC	Near-Midair-Collision
nmi	Nautical Miles
PANS	Procedures for Air Navigation Services
PFD	Primary Flight Display
RA	Resolution Advisory
RVSM	Reduced Vertical Separation Minimums
SARPs	Standards And Recommended Practices
SICASP	SSR Improvement and Collision Avoidance System Panel
SL	Sensitivity Level
SSR	Secondary Surveillance Radar
STC	Supplemental Type Certificate
TA	Traffic Advisory
TCAS	Traffic alert and Collision Avoidance System
TFC	Traffic
TSO	Technical Standard Order
VFR	Visual Flight Rules
VSI	Vertical Speed Indicator
WS	Whisper Shout
XPDR	Transponder

Glossary

ALTITUDE, RELATIVE: The difference in altitude between own aircraft and a target aircraft. The value is positive when the target is higher and negative when the target is lower.

BEARING: The angle of the target aircraft in the horizontal plane, measure clockwise from the longitudinal axis of the own aircraft.

CAS: Generic term for collision avoidance system.

COORDINATION: Data communications between TCAS-equipped aircraft to ensure that they will provide complementary, i.e., nonconflicting RAs.

CPA: Closest point of approach as computed from a threat's range and range rate.

CROSSOVER: Encounters in which own aircraft and the threat aircraft are projected to cross in altitude prior to reaching CPA.

ESCAPE MANEUVER: See resolution maneuver.

FRUIT: See Garble, Nonsynchronous

GARBLE, NONSYNCHRONOUS: Reply pulses received from a transponder that is being interrogated from some other source. Also called fruit.

GARBLE, SYNCHRONOUS: An overlap of the reply pulses received from two or more transponders answering the same interrogation.

INTRUDER: A target that has satisfied the traffic detection criteria.

OWN AIRCRAFT: The TCAS-equipped reference aircraft.

PROXIMITY TARGET: Any target that is less than 6 nmi in range and within $\pm 1,200$ feet vertically, but that does not meet the intruder or threat criteria.

RA: Resolution advisory. An indication given by TCAS II to a flight crew that a vertical maneuver should, or in some cases should not, be performed to attain or maintain safe separation from a threat.

RESOLUTION MANEUVER: Maneuver in the vertical plane resulting from compliance with an RA.

SENSE REVERSAL: Encounter in which it is necessary to reverse the sense of the original RA to avoid a threat. This is most likely to occur when an unequipped threat changes its vertical rate in a direction that thwarts the original RA.

SL: Sensitivity Level. A value used in defining the size of the protected volume around the own aircraft.

SQUITTER: Spontaneous transmission generated once per second by Mode S transponders.

TA: Traffic Advisory. An indication given by TCAS to the pilot when an aircraft has entered, or is projected to enter, the protected volume around the own aircraft.

TA-ONLY MODE: A TCAS mode of operation in which TAs are displayed when required, but all RAs are inhibited.

TARGET: An aircraft that is being tracked by a TCAS-equipped aircraft.

TCAS: Traffic Alert and Collision Avoidance System.

THREAT: An intruder that has satisfied the threat detection criteria and thus requires an RA to be issued.

TRANSPONDER, MODE C: ATC transponder that replies with both identification and altitude data. If the transponder does not have an interface with an encoding altimeter source, only the altitude bracket pulses are transmitted and no altitude data are provided.

TRANSPONDER, MODE S: ATC transponder that replies to an interrogation containing its own, unique 24-bit selective address, and typically with altitude data.

VSI: Vertical speed indicator.

WHISPER-SHOUT (WS): A method of controlling synchronous garble from ATCRBS transponders, through the combined use of variable power levels and suppression pulses.

Bibliography

Additional information on the performance, design, and requirements for TCAS can be found in the following documents.

- [RTCA/DO-185A](#), Minimum Operational Performance Standards for Traffic Alert and Collision Avoidance System (TCAS II) Airborne Equipment
- FAA Technical Standard Order C-119B, Traffic Alert and Collision Avoidance System (TCAS) Airborne Equipment
- FAA Advisory Circular 20-131, Airworthiness Approval of Traffic Alert and Collision Avoidance System (TCAS II) and Mode S Transponders
- FAA Advisory Circular 120-55, Air Carrier Operational Approval and Use of TCAS II
- [ICAO Annex 10](#), Standards and Recommended Practices and Guidance Material for Airborne Collision Avoidance Systems
- [AEEC/ARINC Characteristic 735](#), Traffic Alert and Collision Avoidance System (TCAS)
- [AEEC/ARINC Characteristic 718](#), Mark 2 Air Traffic Control Transponder (ATCRBS/ Mode S)
- [RTCA/DO-197A](#), Minimum Operational Performance Standards for an Active Traffic Alert and Collision Avoidance System (Active TCAS I)
- FAA Technical Standard Order C-118, Traffic Alert and Collision Avoidance System (TCAS I) Airborne Equipment